



**Chhattisgarh State Renewable Energy
Development Agency (CREDA)**
(Dept. of Energy, Govt. of Chhattisgarh)

Near Energy Education Park, Village Fundhar
VIP (Air Port Road) Raipur 492015 (C.G.) Ph.: +91-8370009925, 7717112459

E-mail: CREDA.om@gmail.com, Website: CREDA.co.in

BID DOCUMENT No. 81347/CREDA/HOR/RE-V/2021-22 DT. 27-08-2021

“TENDER FOR STANDARDIZATION OF RATES FOR SUPPLY OF VARIOUS FABRICATION ITEMS USED IN POWER DISTRIBUTION WORKS FOR OPERATION AND MAINTENANCE/NEW PROJECT WORKS OF SOLAR POWER PLANTS INSTALLED BY CREDA ANYWHERE IN THE STATE OF CHHATTISGARH”

Particulars	From Date & Time	To Date & Time	Place
Date of issue of notice inviting bid	07-09-2021 05:00 pm	----	----
Period of availability of bidding document at website	07-09-2021 05:00 pm	07-10-2021 05:00 pm	www.CREDA.co.in/Tenders
Submission of Pre Bid queries in writing	14-09-2021 11:00 am	14-09-2021 05:00 pm	At CREDA Conference Hall, CREDA HO, Raipur
Submission of Online Bid (Technical + e Price Bid)	07-09-2021 05:00 pm	07-10-2021 05:00 pm	https://eproc.cgstate.gov.in
Opening of Technical Bid	08-10-2021 11:00 am	08-10-2021 02:00 pm	At CREDA Conference Hall, CREDA HO, Raipur
Declaration of Eligible Bidders	After conclusion of Technical evaluation		At CREDA Conference Hall, CREDA HO, Raipur
Opening of e- Price Bid	After conclusion of Technical evaluation and declaration of eligible bidders		At CREDA Conference Hall, CREDA HO, Raipur

Bid Document Cost –Rs.5000.00 + 18% GST = Rs.5900.00/-(In words Rupees Five Thousand Nine Hundred Rupees Only) to be deposited in CREDA’s account along with EMD via RTGS/NEFT as a single transaction.

Document can be downloaded from our website www.CREDA.co.in or from Chhattisgarh e-Procurement portal i.e. <https://eproc.cgstate.gov.in>.

CHATTISGARH STATE RENEWABLE ENERGY DEVELOPMENT AGENCY CONTENTS

Section	Description	Page No.
	Cover Page, Contents etc.	1-3
	Notice Inviting BID	4-4
	Check List	5-5
	Details of EMD and Bid Fee	6-6
	Undertaking of the Bidder	7-7
Section-01	Instruction For Bidder	8-12
	Eligibility Criteria	8-8
	EMD/Submission of Documents/Specification Amendments/GST&PAN	9-9
	Analysis of Rate/Registration of Bidder etc.	9-10
Section -02	General Condition of Contract	13-18
	Definitions/Proof of Manufacturer/Contract Document/Manner of execution/ Variations, Additions & Omissions/Inspection	13-13
	Completion work/ Eligible Bidder Default Liability/Force Majeure/Rejection of works etc.	14-14
Section-03	Scope of work and technical specification	19-39
	Specification of GI octagonal Pole	19-20
	Specification of MS pole ,Cable Fixture	20-20
	Specification of stay set,Street Light Bracket,Structure,fencing	21-21
Annexure-01	Drawing of Hot dipped Galvanised Octagonal pole of height 3 Mtr	22-22
Annexure-02	Drawing of Hot dipped Galvanised Octagonal pole of height 4 Mtr	23-23
Annexure-03	Drawing of Hot dipped Galvanised Octagonal pole of height 5 Mtr	24-24
Annexure-04	Drawing of Hot dipped Galvanised Octagonal pole of height 6 Mtr	25-25
Annexure-05	Drawing of Hot dipped Galvanised Octagonal pole of height 7 Mtr	26-26
Annexure-06	Drawing of Hot dipped Galvanised Octagonal pole of height 8 Mtr	27-27
Annexure-07	Drawing of Hot dipped Galvanised Octagonal pole of height 9 Mtr	28-28
Annexure-08	Drawing of Hot dipped Galvanised Octagonal pole of height 10 Mtr	29-29
Annexure-09	Drawing of Hot dipped Galvanised Octagonal pole of height 11Mtr	30-30
Annexure-10	Drawing of Hot dipped Galvanised Octagonal pole of height 12 Mtr	31-31
Annexure-11	Drawing of MS pole of height 5.7 Mtr	32-32
Annexure-12	Drawing of GI pole of height 5.7 Mtr	33-33
Annexure-13	Drawing of GI street light pole,Padestrianpole,Special Decorative Street light pole with street light luminary and street light bracket with height 9Mtr,6 Mtr,4.5Mtr	34-34
Annexure-14	Drawing of GI stay set,Street light bracket,Cable Fixture	35-35
Annexure-15	Drawing of hot dipped Galvanised single arm street light bracket	36-36
Annexure-16	Drawing of hot dipped Galvanised Double arm street light bracket	37-37
Annexure-17	Drawing and technical specification of chain linking fencing	38-39
Section-04		
1	Price Bid,	40-42
2	Draft Agreement Annexure-18	43-47
3	Schedule - I Part-A	48-48
4	Schedule - II Part-B	49-49
5	Schedule - III Part-C	50-50
6	Schedule - IV - Technical Deviations	51-51

Section	Description	Page No.
7	Schedule - V - Past Experience	52-52
8	Annexure-19 Certificate of completion of supply/work	53-53
9	Annexure-20 Format of affidavit	54-55
10	Annexure-21 Benchmark Cost of items	56-59

Ref. No. : 9699 /CREDA/HOR/RE-V/PDN FAB /2021-22

Date : 07/09/2021

NOTICE INVITING BID

CREDA invites sealed Bids for “Standardization of rates for supply of various fabrication items used in power distribution works (PDN) for operation and maintenance/new project works of solar power plant installed by CREDA anywhere in the state of Chhattisgarh” from original fabricator or its only one authorised distributor with 3 years track record in the field of PDN and O&M works, as per following details -

Sl.No.	Item Description	Approximate value of work	Cost of Bid Document fees and EMD	Essentials
1	“Standardization of rates for supply of various fabrication items used in power distribution works (PDN) for operation and maintenance/project works of solar power plant installed by CREDA anywhere in the state of Chhattisgarh”	3.00 Crore	Rs 5,000 (+18% GST) +Rs.1,50,000 = Rs. 1,55,900 /-	As per clause no. 1A to 1G of Eligibility Criteria (Page no.8)
TOTAL		Rs. 3.00 Crore	Rs.1,55,900.00 /	----

The quantity of work is not fixed. The allocation of work will depend on the availability of project to CREDA

Important Events and time schedule for this Bid are as follows –

Particulars	From Date & Time	To Date & Time	Place
Date of issue of notice inviting bid	07-09-2021 05:00 pm	----	----
Period of availability of bidding document at website	07-09-2021 05:00 pm	07-10-2021 05:00 pm	www.CREDA.co.in/Tenders
Submission of Pre Bid queries in writing	14-09-2021 11:00 am	14-09-2021 05:00 pm	At CREDA Conference Hall, CREDA HO, Raipur
Submission of Online Bid (Technical + e Price Bid)	07-09-2021 05:00 pm	07-10-2021 05:00 pm	https://eproc.cgstate.gov.in
Opening of Technical Bid	08-10-2021 11:00 am	08-10-2021 02:00 pm	At CREDA Conference Hall. CREDA HO, Raipur
Declaration of Eligible Bidders	After conclusion of Technical evaluation		At CREDA Conference Hall. CREDA HO, Raipur
Opening of e- Price Bid	After conclusion of Technical evaluation and declaration of eligible bidders		At CREDA Conference Hall. CREDA HO, Raipur

Technical Bid and Price Bid shall be submitted online only at <https://www.eproc.cgstate.gov.in>. Bidders are advised to follow the instructions provided for Registration and e-Submission Process accordingly. (For any query about e-bidding please visit user manual at <https://www.eproc.cgstate.gov.in>)

Details of this Bid are mentioned at Bid Documents which can be downloaded from our website www.CREDA.co.in. The Bidder should have to deposit Bid document cost along with EMD through NEFT/RTGS in the account of CREDA mentioned below.

Bidders are requested to submit Pre-Bid queries with their suggestions/objections/ reservations if any with details so as to avoid any confusion and to ensure clarity and transparency regarding the Bid.

CREDA reserves all rights to accept/reject any or all Bids in full/part without assigning any reasons. Any Amendments in the tender documents shall only be notified through the website of CREDA i.e. www.CREDA.co.in

**Chief Engineer
RE-V, H.O. CREDA
Raipur (CG)**

CHECK LIST OF DOCUMENTS TO BE UPLOADED IN THE E-BIDDING PORTAL

To ensure that your Bid uploaded on the Chhattisgarh e-Procurement portal i.e. <https://eproc.cgstate.gov.in> is complete in all respects, please go through the following checklist & tick mark for the enclosures attached with your Bid –

Sl. No.	Envelope	Description	Complied <small>(For Office Use only)</small>
1.	A. Pre-Qualification	EMD + Tender Document Fee submission form of the bidder confirmed by CREDA (as on page – 6)	
2.		Self-Attested Undertaking of the Bidder as mentioned on Page – 7 of the tender document.	
3.		Copy of original tender document duly signed & with stamp on each page, as a confirmation of acceptance of the Terms & Conditions (T&C).	
4.		PAN, GSTIN issued in the name of the bidder	
5.		Self-certificate from Bidder on not being a debarred from Government contract or a blacklisted company.	
6.		Declaration of conflict of interest - by bidder about any relatives working with CREDA and Affidavit as per Annexure - 20	
7.		Copy of Registration: Certificate (or Acknowledgment) as PDN contractor/Vendor of fabrication items for PDN Works valid for FY 2021-22.	
8.	B. Technical and Financial Qualification	Valid Production certificate issued by Department of Industries and Commerce	
9.		Original Net Worth Certificate and Turnover Certificate duly signed and certified by Chartered Accountant	
10.		Certified copy of work /purchase/supply orders to prove last three financial year's turnover of works done regarding PDN Works/Electric material, Equipment supply work.	
11.		Copy of ITRs and audited balance sheet for last three Financial Years of the Bidder	
12.		Completion and Performance Certificates of PDN Works, Electric material, Equipment Supply work in the name Bidder in Govt. Scheme of CREDA.	
		Undertaking on indigenoussness of components	
13.		Manufacture Authorization certificates of standard items	
14.		Schedule - I Part-A (on page - 49 of bid document)	
15.		Schedule - II Part-B (on page - 50 of bid document)	
16.		Schedule - III Part-C (on page - 51 of bid document)	

Details of EMD and Tender Document Fee

A scanned copy of the EMD and Bid Document fee transaction shall have to be uploaded in the format below on the Chhattisgarh e-Procurement portal. Details uploaded in incorrect format shall be rejected.

Tender No. and Date	
Name of the Bidder	
Bidder's Bank Account Details	
(i) Name of the bank	
(ii) Branch	
(iii) IFSCCode	
(iv) Account No.	
(v) Transaction reference number	
(vi) Date of transaction	
(vii) EMD + Bid Document Fee	Rs. 2,05,900/- (Rs. 2,00,000 + Rs. 5,900)

Name of A/c	CREDA
Bank & Branch Name	ICICI Bank, Panchpedi Naka, Raipur
Bank Account Number	134601000400
Branch IFSC Code	ICIC0001346

(Sign & Seal of the bidder)

***NOTE –**

1. The EMD and the Tender Document Fee shall have to be deposited as a single NEFT/RTGS transaction in CREDA's bank account (amount mentioned above).
2. Bidder's those who have valid MSME Competency Certificate are exempted from submitting the EMD amount mentioned above. They have to only pay the bid document fees

UNDERTAKING OF THE BIDDER

I/We have read carefully and examined the notice inviting Bid, schedule, General Rules and terms and conditions of the contract, special conditions, Schedule of Rates and other documents and Rules referred to in the Bid document for the supply.

I/We hereby Bid my rates for the execution of the work for CREDA as specified within the time stipulated in the schedule in accordance with all aspects with the specifications, designs, drawings and instructions with such conditions so far as applicable.

I/We agree to keep the Bid valid for **One Hundred Eighty (180) days** from the due date of submission thereof and not to make any modifications in its terms and conditions.

A sum of **Rs.....** is hereby forwarded as **Earnest Money** in the form of crossed demand draft / RTGS / NEFT payable to CREDA at Raipur (C.G.). If I/We, fail to commence or complete the Work Ordered in specified time or fail to fulfil the any condition of Bid document, I/We agree that the CREDA shall, without prejudice to any other right or remedy, be at liberty to forfeit the said Earnest Money absolutely. The said Earnest Money shall be retained by CREDA towards security deposit to execute all the works referred to in the Bid documents upon the terms and conditions contained or referred to therein and to carry out such deviations as may be required by CREDA.

I/We hereby declare that I/We shall treat the Bid documents, specifications and other records connected with the work as secret/confidential and shall not communicate information derived there from to any person other than a person to whom I/We have authorized to communicate the same or use the information in any manner prejudicial to the safety of CREDA/Government.

I/We shall abide to all the laws and shall be responsible for making payments of all the taxes, duties, levies and other Govt. dues etc. to the appropriate Govt. departments.

Our GST Registration No. The PAN No. under the Income Tax Act is

I/We shall be responsible for the payment of the respective taxes to the appropriate authorities and should I/we fail to do so, I/we hereby authorize CREDA to recover the taxes due from us and deposit the same with the appropriate authorities on their demand.

Dated:

Signature

Place:

Name of Bidder with seal

Witness :

Signature:

Name:

Postal Address:

.....

SECTION – 1 INSTRUCTIONS FOR BIDDERS

1. ELIGIBILITY CRITERIA :

A. MINIMUM EXPERIENCE

Bidders must have minimum experience in last three financial years i.e. 2018-19 & 2019-20,2020-21 as per the details mentioned below –

S.No.	Details of work	Experience
1	“Standardization of rates for supply of various fabrication items used in power distribution works (PDN) for operation and maintenance/project works of solar power plant installed by CREDA anywhere in the state of Chhattisgarh”	Minimum 03 years experience in PDN and O&M related works in CREDA or other government department/Agency/body of Chhattisgarh only

Bidders will have to submit satisfactory commissioning/functioning report containing complete details from the concerned state/central agencies /department along with bid document. Experience Certificates submitted should be in attached format (as per Annexure-19) **or Other Format containing similar information as in attached format (Annexure-19) shall be considered only in-case of submitted in Hindi / English Language only.** Work order, L.O.I. / L.O.A etc., will not be acceptable.

- B.** Bidders must have a Positive Net worth of Rs.25Lacs as on 31st March 2020 (which is defined as “Net value of the Assets minus (-) Net value of liabilities”). They shall have to submit a **Certified Certificate** duly signed by a qualified and registered Chartered Accountant having UDI number as a proof. Produced certificate must tally with the audited balance sheet.
- C.** Bidders should have an aggregate turnover of minimum **2 Crores** in last three years i.e. 2017-18, 2018-19&2019-20 in SPV Projects (Specifically in PDN works, Fabrication works, Electrical material supply work). Certified copies of the annual returns and audited balance sheet submitted to the Registrar of Companies/ Income Tax Authorities should be enclosed. For the preceding years, a **certified summarised sheet** of turnover certified by registered CA must be enclosed.
- D.** Bidder who is debarred from business by Govt. /Govt. Agency in any state would not be eligible to participate in this bid. A self-declaration should be submitted by the bidder to this effect, failing which bid shall be rejected.
- E.** The bidder shall be the original fabricator or its authorised distributor. The bidder shall have to submit the proof of being original fabricator of items for which he wants to bid.
- F.** The bidder must be registered as PDN contractor/Vendor of fabrication items in CREDA for FY 2020-21.
- G. Additional Eligibility Criteria-** Even though the bidders meet the above qualifying criteria, they are subject to be disqualified if they have:
 - a. Made misleading or false representations in the forms, statements, affidavits and attachments submitted in proof of the qualification requirements; and/or
 - b. Record of poor performance such as abandoning the works, not properly completing the contract, inordinate delays in completion litigation history, or financial failures etc; and/or
 - c. Participated in the previous bidding for the same work and had quoted unreasonably high or low bid prices and could not furnish rational justification for it to CREDA.

2. BIDDING PROCESS –

For ease of accessing the e-bidding website and registration the following is to be done by bidder -

- A.** Visit <https://eproc.cgstate.gov.in>
- B.** **Prospective bidders are requested to download, read and understand the Manuals present on the website so as to clearly understand the bid submission process.**
- C.** The user will be directed to e-bidding page where all information regarding registration is available along with helpline details.
- D.** Technical bid and Price Bid shall be submitted online only at <https://eproc.cgstate.gov.in> latest by **05.00 PM on 07-10-2021**. Bids submitted after scheduled time and date shall not be considered.

3. EMD AND TENDER DOCUMENT FEE-

The EMD and tender Document Fee shall have to be paid via RTGS/NEFT to CREDA’s Account mentioned below as a single transaction.

Name of the A/c	CREDA
Bank & Branch Name	ICICI Bank, Panchpedi Naka, Raipur
Bank Account Number	134601000400
Branch IFSC Code	ICIC0001346

The receipt of RTGS/NEFT against EMD and document fee deposited must be certified from the finance section of CREDA and should be uploaded as part of Envelope-A (Pre-Qualification requirement) on <https://eproc.cgstate.gov.in>.

4. SUBMISSION OF DOCUMENTS -

All the documents including technical and financial Bid should be submitted online on Chhattisgarh e-Procurement portal <https://www.eproc.cgstate.gov.in> as per the items mentioned in the checklist on page no. 5 in this bid. Bidders are advised to finish all the bidding portal related activities such as registration, USB certificate/token approval, payments etc. so as to avoid last minute difficulties during the bid submission. Bidders are also advised to make themselves fully aware with the bid submission mechanism to avoid last minute hassles and doubts during bid submission. CREDA shall only entertain genuine technical issues/glitches, provided that the bidder submits evidence regarding the same.

5. SPECIFICATION AMENDMENTS -

The Specifications of items should be as per as Specified in the Bid. If any amendments are issued by CREDA in due course of time, in this context, then those shall be applicable under this Bid.

6. GST & PAN -

Bidder shall have to submit copies of GST registration number and PAN numbers issued by the appropriate authority.

7. THE BID -

The Pre-Qualification, Technical-Financial Qualification Documents and Price Bid, other related documents must be uploaded in the portal i.e. <https://eproc.cgstate.gov.in> **from 05:00 PM 07-09-2021 to 05:00 PM dated 07-10-2021**. Nobody is authorized to receive or grant receipt for Bid delivered on behalf of CREDA. **Bid received through any other means shall not be considered and shall be rejected.**

8. ANALYSIS OF RATE -

- A.** Bidder should quote their rates considering variation of site conditions and all other factors in price of different components and keeping the quantum and quality of work in mind. Benchmark cost is attached here with Annexure- 21.
- B.** Bidder shall have to ensure that the rates quoted are not lower than 90% of the benchmark cost as attached in this bid in Annexure IV, rate(s) quoted below 90% of the benchmark cost shall be considered as unbalanced rate.
- C.** If the successful bid is unbalanced in relation to the benchmark cost as stated in Annexure- 21 by more than 10%, then the successful bidder shall have to provide Additional Performance Security (APS) to the extent of difference of the threshold cost (mentioned in point ‘B’) above and rates quoted by the successful bidder for total allocable quantity in such categories in which he has submitted unbalanced bid, in the form of Demand Draft/RTGS issued by approved scheduled bank in favour of CREDA.
- D.** The Additional Performance Security (APS) shall be retained by CREDA and the same shall be returned after successful completion of allocated work. Those other bidders, who accept the L1 Rates, are also required to submit Additional performance security for allocated work.
- E.** Selection of L-1 Rates: - The Successful bidder who found to be L1 (as manner described in this tender document, Clause no. – 33 of Section-II), shall be offered allocated quantity of fabrication

items used in PDN works (as described in this tender document, Clause no.-33 of Section-II). L1 bidder shall have to accept the offer of CREDA within 10 days along with laid down “ADDITIONAL PERFORMANCE SECURITY”, this APS amount of complete allocated quantity shall be submitted at the time of Agreement. The amount of APS will be communicated to L1 bidder along with acceptance letter. Highly unbalanced rate shall not be considered while deciding final approved rates.

- F.** If L1 bidder refuses to accept the offer and to deposit intended APS within the prescribed time, then his bid will be rejected by sanctioning authority and earnest money shall be forfeited and blacklisted for 2 years and debarred to participate in any tender and any activity of CREDA till further orders.
- G.** In case L1 bidder accept the offer and deposit the APS, L1 rates of the pumps will be fixed for rest of the successful bidders. Now other bidder shall be offered rest quantity of pumps (as prescribed in this tender document, Clause No. - 33 of Section-II).
- H.** In case, L1 bidder refuses to accept the offer and doesn't deposit the prescribed APS, offer letter shall be sent to the L2 bidder on L2 rates. Same process shall be repeated till the final rates are fixed.
- I.** By the process mentioned above the final rates will be fixed and shall be offered to other successful bidders.
- J.** The APS shall be submitted by other successful bidder before sanction of allocated fabrication items used in PDN works in the supply work.
- K.** If the bidder fails to complete the work or left the work incomplete, this Additional Performance Security (APS), S.D. and EMD shall be forfeited by the CREDA, the agreement shall be terminated and bidder shall be blacklisted and debarred to participate in any tender and any activity of CREDA till further orders.

9. REGISTRATION OF BIDDER –

Bidders should have a valid registration certificate as PDN contractor/Vendor for supply of various fabrication items in CREDA for FY 2021-22. Only fabricator or its authorised distributor shall be allowed to participate in the tender. In case of multiple distributor/dealer of a fabricator participates in the tender then the tender of all dealers/distributors including fabricator shall be rejected.

10. VALIDITY -

Full descriptive particulars and complete specifications should accompany the offer. Offers should be kept open for acceptance for at least **180 days** from the date of opening. After finalization of this Bid the approved rates shall be valid till one year from the date of finalisation; however CREDA shall have liberty to increase or decrease this validity if needed.

11. TERMS & CONDITIONS -

- A.** The terms, conditions and specifications mentioned in Bid document shall be binding on the Bidders and no condition or stipulation contrary to the conditions shall be acceptable. It may please be noted that the Bidders who do not accept terms and conditions stipulated in this Bid documents, their offers shall be liable to be rejected out-rightly without assigning any reason whatsoever.
- B.** Each page of Bid document & enclosures shall be signed by the Bidder and seal affixed. All the pages of the documents issued must be submitted along with the technical offer. In case of any corrections / alterations in the Bid, the Bidder should attest the same; otherwise Bids may not be considered.
- C.** Bidders are also instructed to submit their Bids in properly arranged manner (with index, proper paging and with flags on important documents). Incomplete, lose, conditional or improper arranged Bids will not be accepted.

12. CREDA RESERVES THE RIGHT -

- (i)** To reject or accept any or all Bids fully or partly without assigning any reason on the

- grounds considered advantageous to CREDA, whether it is the lowest Bid or not.
- (ii) To split the quantities against the Bid further for the same items/work. No reason will be assigned by CREDA for this and will be binding on the Bidders.
 - (iii) To increase or decrease of aggregate quantities up to 100 % as per discretion or circumstances.
 - (iv) Due to large quantum of supply & limitation of the time period for completion of the supply/works CREDA may take consent from other Bidders if they agree to work on rates standardized by CREDA.
 - (v) CREDA may undergo agreement with those eligible Bidders who give consent to work on rates standardized by CREDA and may allocate work to them. Rates approved through this Bid may be standardized for all eligible Bids to work in **year 2021-22 & 2022-23** and shall be valid till **31-03-2023**. However CREDA reserves right to curtail or extend this period.

13. COMMUNICATIONS -

- A. All the communication between Bidder and CREDA shall be in writing. Notice sent by Fax or other Electronic means shall be effective on confirmation of the transmission. Notice sent by registered post or speed post shall be effective of delivery or at expiry of normal delivery period as under taken by Postal Service.
- B. Offers through Telegraph/Fax/Emails/Post/Courier or open offers etc. received shall be summarily rejected.

14. BID DOCUMENT FEE AND EARNEST MONEY-

- A. Each Bidder should submit Bid Document Fee and earnest money in the form of Demand Draft/Pay Order or RTGS/NEFT as mentioned in the NIT vide **81347/CREDA/HOR/RE-V/PDN FAB/2021-22 DT. 27-08-2021**, in a separate envelope as prescribed at **point no. 04 of page 08**, else they will summarily be rejected and returned. Bid Document Fee & EMD submitted in any other form e.g. **Cash/Bank Guarantee/FDR /TDR etc. shall not be accepted.**
- B. MSME unit registered for manufacturing or service of PDN/electrical/electronic items or its components in Chhattisgarh state and public sectors of government are exempted from EMD subjected to submission of valid document (Production Competency Certificate).

15. PRE-BID MEETING -

- A. Pre-bid queries are required to be submitted on **14-09-2021 up to 5:00 PM** at CREDA HO Raipur to clarify doubts so that all doubts and confusions are resolved before the submission of Bid.
- B. All suggestions, doubts, confusion, request, queries etc., shall have to be presented to CREDA in writing on or before **14-09-2021 till 5:00 PM**. After that any representation in this regard shall not be considered.
- C. The purpose of pre-bid queries is to clarify issues and to answer questions in any matter that can be raised at that stage. The responses against queries if required will be uploaded on website of CREDA and the e-bidding portal for information of bidders. Any modification of the bidding document which may become necessary as a result of pre-bid queries shall be part of original Bid document and communicated through corrigendum uploaded on www.CREDA.co.in and <https://eproc.cgstate.gov.in>.

16. TECHNICAL CRITERIA -

Bidder shall have to give a self declaration that all the fabrication items are conforming to the latest ISI standards and BIS standards.

17. FORFEITURE OF EARNEST MONEY DEPOSIT -

It should be clearly understood that in the event of Bidder failing to enter into the agreement in the prescribed format on their quoted rates and also fails to execute assigned works under any Scheme of CREDA, within stipulated time, if he is so communicated within the validity period of the offer, the full amount of earnest money will be forfeited and Bidder shall be debarred from future business with CREDA. CREDA's decision in this regard will be final and binding on the Bidders.

18. PRICE OF SUPPLY OF PDN FABRICATION ITEMS -

- I. The Price quoted for all items must be with one year warranty. The GST shall be paid extra as per prevailing rate. The prices shall be filled exactly as per **Price Bid enclosed**.
- II. Any change in GST shall be become applicable during the period of contract.

19. ENGINEERING DOCUMENT -

Bidders will have to submit Engineering Documents with technical details, Specifications of components and make etc. to CREDA for approval, as and when asked by CREDA. Supply/work may only be started out only after approval of the Engineering Document/Drawing.

20. INSPECTIONS -

CREDA reserves right to inspect the material at Godowns / Temporary Stores before dispatch and also at works sites.

21. TAX OBLIGATIONS -

CREDA shall deduct TDS for Income Tax, applicable cess on Civil Work etc. under various acts and deposited with the appropriate authority. Costs and taxes before execution of agreement with CREDA so as to ensure tax deposition as per Government Rules accordingly.

22. JURISDICTION OF THE COURT -

Any dispute arising out of the contract shall be subject to the jurisdiction of Hon'ble High Court of Chhattisgarh.

23. CORRUPT OR FRAUDULENT PRACTICES -

- i. CREDA requires the bidder to strictly observe the laws against fraud and corruption in force in India, namely, Prevention of Corruption Act, 1988.
- ii. It is required that each bidder (including their respective officers, employees and sub contractors) adhere to the highest ethical standards, and report to the Government/ Department all suspected acts of fraud or corruption or coercion or collusion of which it has knowledge or become aware, during the tendering process and throughout the negotiation or award of contract.

SECTION - 2

GENERAL CONDITIONS OF CONTRACT

1. **DEFINITIONS -**

In writing General Conditions of Contract, the specifications and bill of quantity, the following words shall have the meanings hereby indicated, unless there is something in the subject matter or content inconsistent with the subject.

- CREDA shall mean the Chhattisgarh State Renewable Energy Development Agency represented through the Chief Engineer.
- Work shall mean any work entrusted to the Bidder as mentioned in the scope of work and Work Order.
- The "Engineer in charge" shall mean the Engineer or Engineers authorized by CREDA for the purpose of this contract. Inspecting Authority shall mean any Engineering person or personnel authorized by CREDA to supervise and inspect the erection of the SPV dual Pump.
- "The Eligible SI/Bidder" shall mean the Bidder awarded with the contract or their successors and permitted assigns. Contract Price shall mean the sum named in or calculated in accordance with the provisions of the contract as the contract price. General Conditions shall mean the General conditions of Contract.
- "Specifications" shall mean the specifications annexed to these General Conditions of contract and shall include the schedules and drawings attached thereto or issued to the eligible bidder from time to time, as well as all samples and pattern, if any,
- "Month" shall mean calendar month. "Writing" shall include any manuscript, typewritten, printed or other statement reproduced in any visible form whether under seal or written by hand.

2. **PROOF OF MANUFACTURER -**

Those bidders who are also manufacturers of an important component of fabrication items shall have to submit proof of their factory, SSI Registration and list of Machineries and Equipment's.

3. **CONTRACT DOCUMENT -**

The term "Contract" shall mean and include the General conditions, specifications, schedules, drawings and Work Orders etc., issued against the contract schedule of price or their final general conditions, any special conditions applying to the particular contract specification and drawings and agreement to be entered into. Terms and conditions not herein defined shall have the same meaning as are assigned to them in the Indian contract Act or any other Act in vogue or by any person of common knowledge and prudence.

4. **MANNER OF EXECUTION -**

Execution of work shall be carried out under Government Mode Scheme of CREDA in an approved manner as outlined in the technical specifications or where not outlined, in accordance with desired Specifications laid down by CREDA, to the reasonable satisfaction of the Engineer.

5. **VARIATIONS, ADDITIONS & OMISSIONS -**

CREDA shall have the right to alter, amend, omit, split or otherwise vary the quantum of work, by notice in writing to the Bidder. The eligible Bidder shall carry out such variation in accordance with the rates specified in the contract so far as they may apply and where such rates are not available; those will be mutually agreed between CREDA and the eligible Bidder.

6. **INSPECTION -**

- A. The Engineer-in-Charge or his authorized representative(s) shall be entitled at all reasonable times to inspect and supervise and test during supply and commissioning. Such inspection will not relieve the eligible bidder from their obligations under this contract.

- B. Material can be inspected before dispatch or in transit by the authorized representatives of CREDA at the factory / godown at the cost of the eligible bidder, if desired by CREDA.
- C. CREDA will undertake real time performance and quality test of randomly selected **Items** and its components during the course of execution as per the specifications and guidelines laid by CREDA to ensure quality items/work.

7. **COMPLETION OF WORK -**

Time being the essence of contract, the supply of the Items/work shall be completed within the time schedule prescribed in the Work Order.

8. **ELIGIBLE BIDDER'S DEFAULT LIABILITY -**

CREDA may by written notice of default to the eligible bidder, terminate the contract in circumstances detailed hereunder -

- (a) If in the opinion of the CREDA, the eligible bidder fails to complete the supply/work within the time specified in the supply/work Order or within the period for which extension has been granted by CREDA to the eligible bidder.
- (b) If in the opinion of CREDA, the eligible bidder fails to comply with any of the provisions of this contract.
- (c) In the event of CREDA terminating the contract in whole or in part as provided in paragraph (a) above, CREDA reserves the right to engage another eligible bidder or agency upon such terms and in such a manner as it may deem appropriate and the eligible bidder shall be liable to CREDA for any additional costs or any losses caused to CREDA as may be required for the supply of the Items and or for penalty as defined under this Bid document until such reasonable time as may be required for the final completion of the work.
- (d) In the event CREDA does not terminate the contract as provided in paragraph (a) the eligible bidder shall continue performance of the contract, in which case he shall be liable to CREDA for penalty for delay as set out in this Bid document until the work is completed.

9. **FORCE MAJEURE -**

The eligible bidder shall not be liable for any penalty for delay or for failure to perform the contract for reasons of FORCE MAJEURE such as of God, acts of public, enemy, LWE problems, acts of government, cyclone, fires, floods, epidemics, quarantine restrictions, strikes, freight embargoes provided that if bidder shall submit delay notice with appropriate cause of delay to the CREDA in writing within **15 days** of force majeure. CREDA shall verify the facts and may grant such extension as facts justify. Delay in supply of any accessories of items etc. by the related vendors, to whom the Bidder has placed order, shall also not be treated as force majeure.

10. **REJECTION OF WORKS -**

In the event of any of the material supplied/work done by the eligible bidder is found defective in material or workman ship or otherwise not in conformity with the requirements of this contract specifications, CREDA shall either reject the material and/or work and advise the eligible bidder to rectify the same. **CREDA may impose penalty for such rejection up to the 200% cost of the entire item/work. Habitual/repeated offenders shall be black listed/debarred to participate in the any Bid/ Activity of CREDA till further orders.** The eligible bidder on receipt of such notices shall rectify or replace the defective material and rectify the work free of cost. If the eligible bidder fails to do so CREDA may -

- a) At its option replace or rectify such defective materials and/or work and recover the extra cost so involved from the eligible bidder plus **15%** service charges of the cost of such rectification, from the eligible bidder and/ or terminate the contract for balance work/ supplies with enforcement of penalty **as stated above.**
- b) Defective materials/workmanship will not be accepted under any conditions and shall be rejected outright without compensation. The eligible bidder shall be liable for any loss/damage sustained by CREDA due to defective work **with enforcement of penalty as stated above.**

11. EXTENSION OF THE TIME -

If the completion of installation is delayed due to any reason beyond the control of the eligible bidder, the eligible bidder shall without delay give notice to the CREDA in writing of his claim for an extension of time. CREDA on receipt of such notice may or may not agree to extend the contract/delivery/completion date of the items/works as may be reasonable but without prejudice to other terms and conditions of the contract.

12. MAKES OF EQUIPMENTS TO BE USED IN THE WORK -

(I) The items shall be made in India.

(II) The eligible bidder has to ensure that equipment's as per Technical Requirements of guidelines of CREDA as complied with. The material/works for which CREDA/MNRE or BIS/IEC or ISI specification is not available, engineer-in-charge of the works will examine and approve the material/works, preferably of all makes on which CREDA has report of satisfactory performance. Test certificates for items should be submitted to the engineer-in-charge of the works before installation of the same.

(III) Successful bidder upon issue of LOI must submit Manufacture Authorization Form (MAF) From manufacture of electrical and electronics items/equipment which he is going to supply, **no payment shall be made if he fails to do so.**

(IV) Eligible bidder should submit warrantee Agreement for one year for Items with manufacturer or distributors certified by the manufacturer before supply of items and execution of works, for any manufacturing defects or bad workmanship.

13. WARRANTEE PERIOD AND POST SUPPLY SERVICES -

A. The work done/material supplied by the eligible bidder should be warranted for satisfactory operation and against any defect in material and workmanship including Items and other balance of equipment's, for a period of **1(one) years**, from the date of supply/completion of the items/work.

B. The above warrantee certificates shall be furnished to the CREDA for approval. Any defect noticed during this period should be rectified by the supplier free of cost upon written notice from CREDA provided such defects may be due to bad workmanship or bad materials used.

C. The warrantee period shall be extended by the period during which the items/work remains non-operative due to reasons within control of the eligible bidders.

D. This warrantee must be an unconditional onsite warrantee and the eligible bidder will have to replace the defective material within **7 days** positively from the date of information given to him.

E. Care should necessarily be taken to make the Items operational, once the reporting of the fault/non-operational status is done, within a week. If the items is not made operational within **7 days** CREDA may rectify the same at the cost of bidder and the warrantee period shall be extended for a month for the same.

F. Eligible Bidder shall have to establish their service stations in headquarter and shall have to keep sufficient quantity of spares and man power to ensure proper service network for taking care of smooth functioning of items supplied by them. Eligible bidder shall have to give a toll free number to register complaints.

14. TERMS OF PAYMENT -

The following terms of payment shall apply for the Bid -

A. **97%** of the eligible payment as per the supply/work Order after satisfactory supply and performance testing of the works at site with proper handing over.

B. Balance **3%** of the eligible payment (Without GST) shall be retained by CREDA as Performance Security for a period of **12 months**.

15. PENALTY FOR DELAY IN COMPLETION OF CONTRACT -

If the eligible bidder fails to complete the assigned work within the schedule time specified in the sanction order or any extension granted there to, CREDA will recover from the bidder as penalty a sum of half percent (0.5%) of the system price excluding GST/Tax for every delayed system per week. For this purpose, the date of taking over shall be reckoned as the date of completion. The total penalty shall not exceed 5% (Five Percent) of the cost.

However, imposition of such penalty shall be discretion of CREDA. This penalty may be decrease, increase or waved off due to various justified reasons on ground with recommendations of field staff on record. Period declared as lockdown or local quarantine /containment zones due to Covid-19 pandemic shall be waved off for the purpose of penalty.

Review of the progress of supply of the fabrication items used in PDN works allocated to bidders shall be done time to time by CREDA and if the progress of supply of fabrication items used in PDN works is found unsatisfactory, the allocation of entire remaining supply or their part of can be re-allocated to other bidders as per discretion of CREDA.

16. SECURITY DEPOSIT (SD) -

- A. The Earnest Money shall be retained by CREDA for a period up to which the tender/RC is live .
- B. Beside this,3% of the cost shall also be retained as SD during the period of warrantee. No interest shall be payable on the Security Deposit.
- C. `Period for which EMD and SD are to be retained may be extended in case the warrantee period is extended due to non performance of the system.

17. INSURANCE -

- A. The eligible bidder shall arrange insurance coverage for the materials at his/ beneficiary's custody for the work under execution and successful commissioning and subsequent handover to the beneficiary. The eligible bidder shall take up insurance or such other measures for the manpower so as to cover the claim for damage / accident under workmen's compensation Act and other applicable State/Central laws. CREDA shall not bear any responsibility on this account.
- B. Eligible bidder shall arrange for insurance coverage for complete material supplied during warrantee period from the date of supply/work. Insurance should cover for damage and theft. In case of such incidence, bidder must replace the lost/damaged part within **7 days** from the date of intimation.

18. PENALTY DUE FROM THE ELIGIBLE BIDDER -

All costs of damages and delays for which the eligible bidder is liable to the CREDA will be deducted from any money due to the eligible bidder including the security deposit of any project under CREDA.

19. ELIGIBLE BIDDER'S RESPONSIBILITY -

Notwithstanding anything mentioned in the specifications of subsequent approval or acceptance of the items by CREDA, if any, the ultimate responsibility for satisfactory performance of the entrusted work shall rest with the eligible bidders. If in any case the eligible bidder does not complete the Supply/work as per the supply/work Orders issued to them then CREDA may take over the task & complete the project at the risk and cost of eligible bidder.

20. RESPONSIBILITY TO RECTIFY THE LOSS AND DAMAGE -

If any loss or damage occurs to the work or any part thereof or materials/plant/equipment's for incorporation therein the period for which the eligible bidder is responsible for the cause thereof or from any cause whatsoever, the eligible bidder shall at his own cost rectify/replace such loss or damage, so that the permanent work confirms in every respect with the provision of the contract to the satisfaction of the Engineer. The eligible bidder shall also be liable for any loss or damage to the work/equipment's occasioned by him in course of any operation carried out to him during performing the contract.

21. RESPONSIBILITY TOWARDS THE WORKMAN OR OUT SIDERS –

- A. **The eligible bidder shall have to take insurance coverage from any authorized Insurance Company against Workmen compensation due under Workmen Compensation Act and submit copy of the insurance document before issuance of Work Order.**

- B.** The eligible bidder shall ensure all safety measures during execution and repairs of the work. CREDA, will, in no case be responsible for any accident fatal or non-fatal, caused to any workman or outsider in course of transport or execution or repairs of work.
- C.** All the expenditure including treatment or compensation will be entirely borne by the eligible bidders. The eligible bidder shall also be responsible for any claims of the workers including, labour payments PF, Accidental Insurance, Gratuity, ESI & other legal obligations.
- D.** CREDA shall have all rights to deduct such claims of payments from bidder in case of complaints of such violations.

22. NON-ASSIGNMENTS -

The eligible bidder shall not assign or transfer the supply/workorders issued as per this contract or any part thereof without the prior approval of CREDA.

if eligible bidder transfer/assigned/sublet full or any part of work allocated to him without prior permission from CREDA in writing to any third party shall be liable to debar/black listed from any Bid/Activity of CREDA till further orders.

23. CERTIFICATES NOT TO AFFECT RIGHTS OF CREDA -

The issuance of any certificate by CREDA or any extension of time granted by CREDA shall not prejudice the rights of CREDA in terms of the contract nor shall they relieve the eligible bidder of his obligations for due performance of the contract.

24. SETTLEMENT OF DISPUTES THROUGH ARBITRATION -

A. Except as otherwise specifically provided in the contract, all disputes concerning questions of fact arising under the contract shall be decided by the Chief Executive Officer (CEO), CREDA provided a written appeal by the eligible bidder is made to CREDA. The decision of the CEO, CREDA shall be final and binding to the all concerns.

B. Any dispute or difference including those considered as such by only of the parties arising out of or in connection with the contract shall be to the extent possible be settled amicably between the parties. If amicable settlement cannot be reached then all disputed issues shall be settled by arbitration.

25. LAWS GOVERNING CONTRACT -

The contract shall be constituted according to and subject to the Laws of India and jurisdiction of the High Court of Bilaspur, Chhattisgarh.

26. LANGUAGE AND MEASURES -

All documents pertaining to the Contract including specifications, schedules, notice correspondences, operating and maintenance instructions, drawings or any other writings shall be written in English / Hindi language. The metric system of measurement shall be used in this contract.

27. CORRESPONDENCE -

A. Any notice to the eligible bidder under the terms of the contract shall be served by registered mail to the registered office of the eligible bidder or by hand to the authorized local representative of the eligible bidder and copy by post to the eligible bidder's principal place of business.

B. Any notice to CREDA shall be served to the Chief Engineer, CREDA Raipur in the same manner.

28. SECRECY -

The eligible bidder shall treat the details of the specifications and other documents as private and confidential and they shall not be reproduced without written authorization from CREDA.

29. AGREEMENT -

The successful eligible bidder shall have to enter into an agreement with the CREDA in the approved contract agreement form within **10 days** of the receipt of call from CREDA.

30. DECLARATION OF CONFLICT OF INTEREST –

A. The bidder shall not be permitted to Bid for the work if the section of HO CREDA (responsible for implementation of work) in which his near relative is posted. Furthermore Successful Bidder shall not be given work in the district in which his near relative is posted. Bidder shall also intimate the names of his near relatives working in the CREDA. Bidder shall also intimate the name of persons who are working with him in any capacity and who are near relatives to any employee in CREDA. Any breach of this condition by bidder would render himself liable to be blacklisted for three years and removed from approved list of bidder.

Note: - By the term near relatives is meant Wife, Husband, Parents and son , Brother, Sister, Brother-in-law, Father-in-law, Mother-in-law etc.

B. Bidder must produce an affidavit (Annexure-20) stating the names of retired/removed employee of CREDA (if any) in his employment who retired /removed within last two years, if in case there is no such person in his employment, his affidavit should clearly state this fact. This affidavit is mandatory, if it is not produced along with the bid, the bid shall be rejected.

31. BID EVALUATION CRITERIA -

C. Offers of only those parties, who are found qualified based on Eligibility Criteria and Techno-commercial Bid, will be taken into further consideration and financial bid of only those parties who are qualifying the criteria of Techno-commercial Bid will be opened.

D. Other things being equal, the lowest rates shall normally be preferred, but CREDA shall have rights and liberty to amend/lower the rates.

E. **Conditional Bids shall not be accepted.**

F. However CREDA shall have rights and liberty to call any /other parties to work on approved rates as and when requires in accordance with quantum of work and scheduled time limits for completion of targets.

32. EVALUATION OF PRICE BID -

Price bid shall be evaluated on the basis of Quoted rates. Lowest rates of each category of Items/works shall be considered however CREDA shall have discretionary power to amend/lower the rates.

33. ALLOCATION OF TARGETS AND AREA OF WORK -

The supply shall preferably allotted to eligible bidders on L-1 rates subjected to rate reasonability however the CREDA has sole discretionary power to award work to any other eligible bidder on L-1 rates if he agreed to supply/work on L-1 rates. The allocation of work will be based on the project, work and demand received from field offices of CREDA.

34. BID REJECTION -

If financial bid of a bidder has been opened on the basis of technical bid of a bidder which has been determined to be substantially responsive to the bidding document and in latter stage it is found that bidder does not meet the eligibility criteria or the technical bid is found substantially non-responsive, CREDA reserves rights to reject such bid of a bidder any time.

We (on behalf of Eligible Bidder) have read all the above stated details & accept to comply with it in total

(Name, Signature & Seal of the SI)

SECTION-3

SCOPE OF WORK AND TECHNICAL SPECIFICATION

The scope of work includes the supply of material at site ordered by CREDA with in a scheduled time period. The Technical specification of items are:-

S. No.	Name of Fabrication Item	Description of Item
1	Octagonal GI Pole	Supply of hot dipped galvanized (in single dip to average 80 micron) Octagonal polemade of 3mm thick steel plate having bases plate 200x200x12mm, Window and flush cover with hacking arrangement at height from base for cable termination block, pole suitably reinforced with welded steel section at window cut section to make the strength of pole unaffected, with 4 nos. 450 mm long, 16mm dia hot dipped GI foundation bolts (EN8 grade)
1.1		3Meter height Approx Min Weight 50-52 kg bare pole
1.2		4Meter height Approx Min Weight
1.3		5Meter height Approx Min Weight
2		Supply of hot dipped galvanized (in single dip to average 80 micron) Octagonal polemade of 3mm thick steel plate having bases plate 200x200x12mm, Window and flush cover with hacking arrangement at height from base for cable termination block, pole suitably reinforced with welded steel section at window cut section to make the strength of pole unaffected, with 4 nos. 600 mm long, 20mm dia hot dipped GI foundation bolts (EN8 grade)
2.1		6Meter height Approx Min Weight 60-62 kg bare pole
2.2		7Meter height Approx Min Weight
3		Supply of hot dipped galvanized (in single dip to average 80 micron) Octagonal polemade of 3mm thick steel plate having bases plate 200x200x16mm, Window and flush cover with hacking arrangement at height from base for cable termination block, pole suitably reinforced with welded steel section at window cut section to make the strength of pole unaffected, with 4 nos. 600 mm long, 20mm dia hot dipped GI foundation bolts (EN8 grade)
3.1		9Meter height Approx Min Weight
4		Supply of hot dipped galvanized (in single dip to average 80 micron) Octagonal polemade of 3mm thick steel plate having bases plate 250x250x16mm, Window and flush cover with hacking arrangement at height from base for cable termination block, pole suitably reinforced with welded steel section at window cut section to make the strength of pole unaffected, with 4 nos. 750 mm long, 24mm dia hot dipped GI foundation bolts (EN8 grade)
4.1		10Meter height Approx Min Weight

5	Octagonal GL Pole	Supply of hot dipped galvanized (in single dip to average 80 micron) Octagonal pole made of 3mm thick steel plate having bases plate 275x275x16mm, Window and flush cover with hacking arrangement at height from base for cable termination block, pole suitably reinforced with welded steel section at window cut section to make the strength of pole unaffected, with 4 nos. 750 mm long, 24mm dia hot dipped GI foundation bolts (EN8 grade)
5.1		11Meter height Approx Min Weight
5.2		12Meter height Approx Min Weight
6	MS Pole	Fabrication and supply of M.S. Pole, with ISI "B" Class M.S. Pipe as per drawing and specification enclosed with all material and with two coat Zink Chromate primer and tow coat Silver/Aluminium Paint of standard brand 12" x 12" base plate (10 thickness) foundation in MS Pole with stiffner and 4 Nos. T-bolt with double nuts (20 mm. Dia& 900 mm. Length. Nut bolt arrangement in 4 feet from the bottom of pole.
6.1		5.7 Meter Height Approx Min weight 40-42 kg bare pole
6.2		7.5 Meter Height Approx Min Weight 80-82 kg bare pole
7		Fabrication & Supply of ISI mark G.I.pipe poles made of "B" class making necessary hole for cable entry and providing earthing stud(Welded at specified height) as per specifications and drawing
7.1		5.7 Meter Height Approx Min weight 45-48 kg bare pole
7.2		7.5 Meter Height Approx Min weight 62-65 kg bare pole
8	Decorative pole with street light bracket and luminary	Fabrication and supply of ISI mark G.I. special type pedestrian pole as per drawing with 25 watt street light luminary warm LED (4.5 Mtr height) with PU painting as per CREDArequirement,Approx Min Weight -35-38kg including bracket
9		Fabrication and supply of ISI mark G.I. pedestrian pole as per drawing with street light bracket with PU painting as per CREDA requirement (6 Mtr height),approx Min Weight 45-48 kg including bracket
10		Fabrication and supply of ISI mark G.I. street light pole as per drawing with street light bracket (9 Mtr height) with PU painting ,Approx min weight -86-89kg including bracket
11	GI Cable Fixture	Fabrication and supply of ISI mark G.I.cable fixtures Type A,hot dipped galvanized Min Weight:-4.5Kg
12		Fabrication and supply of ISI mark G.I.cable fixtures Type B, hot dipped galvanized Min Weight:-3.0Kg
13	GI Pipe	Fabrication and Supply of ISI mark G.I.pipe "B" Class arrangement(850 mm length and 50 mm dia)for underground cabling in pole near foundation with suitable G.I.clamp for holding ISI mark G.I.pipe "B" Class

14	Stay Set	Fabrication & Supply of G.I. stay sets as per specifications and drawing
15	Street Light Bracket	Fabrication & supply of ISI mark G.I.pipe "B" Class street light bracket for mounting Street Light fittings as per specifications and drawing.
16		Fabrication & supply of ISI mark hot dipped G.I. Single arm street light bracket(Size OD 48.3x3.20 MM Thick,Length 1.5Mtr Centre to top with 15' inclination from horizontal plane) for mounting Street Light fittings in octagonal pole of various height as per specifications and drawing.Pipe Material IS:2062
17		Fabrication & supply of ISI mark hot dipped G.I. Double arm street light bracket(Size OD 48.3x3.20 MM Thick,Length 1.5Mtr Centre to top with 15' inclination from horizontal plane) for mounting Street Light fittings in octagonal pole of various height as per specifications and drawing.Pipe Material IS:1161,YST:210Mpa
18	Wall Mount Bracket	Fabrication & supply of ISI mark G.I.pipe "B" Class Wall Mount Brackets as per specifications and drawing
19	Structure	Fabrication and supply of hot dipped galvanised structure for mounting of solar modules or any other structure as per specification,size and design given with all required material,drilling work and two coat steel primer zinc chromate of standard quality
20	Fencing	Fabrication and supply of fencing of 10 gauge chain link wire mesh of 75X75 mm opening, fitted with 50X50X5 mm vertical M.S. Angle at spacing of 2.5 mtr& 35X35X5 mm horizontal M.S. Support. Every set of fencing will have one M.S. Angle framed gate with same chain link wire mesh with locking arrangement and two extra posts. Three lane barbed bolts, washer and nut as per enclosed design drawing and specification with two coat steel primer zinc chromate silver/aluminium paint of standard brand with installation and fitting of fencing with grouting the poles in 1:2:4 P.C.C. of size 0.45X0.45X0.60 mtr. for given requirement with complete civil material

The complete descriptive drawing of above fabrication items are listed as under:-

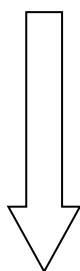

Detailed Drawing of 3m height octagonal pole.

(Annex-01)

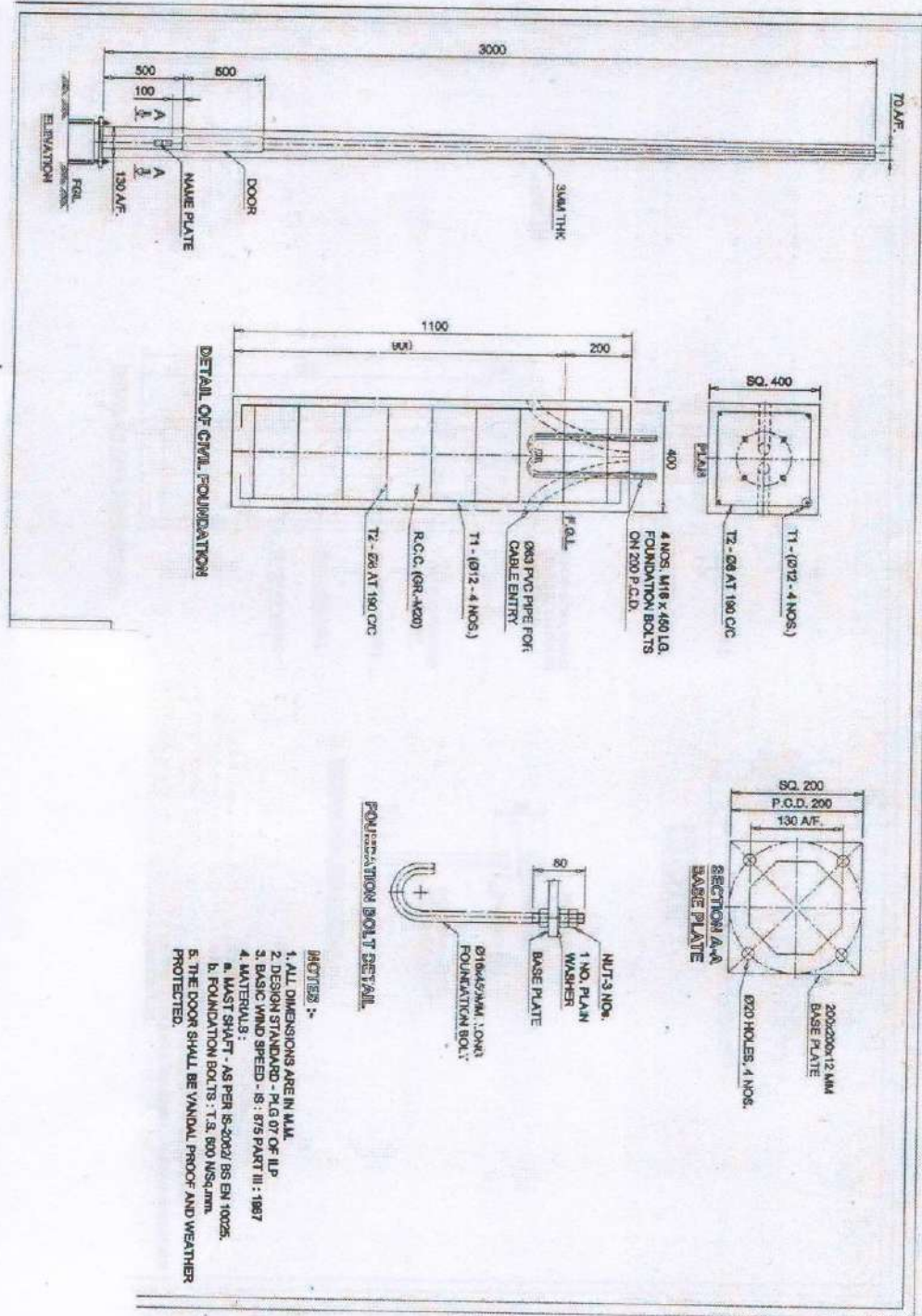

1)
Detailed Drawing of 4m height octagonal pole.

(Annex-02)

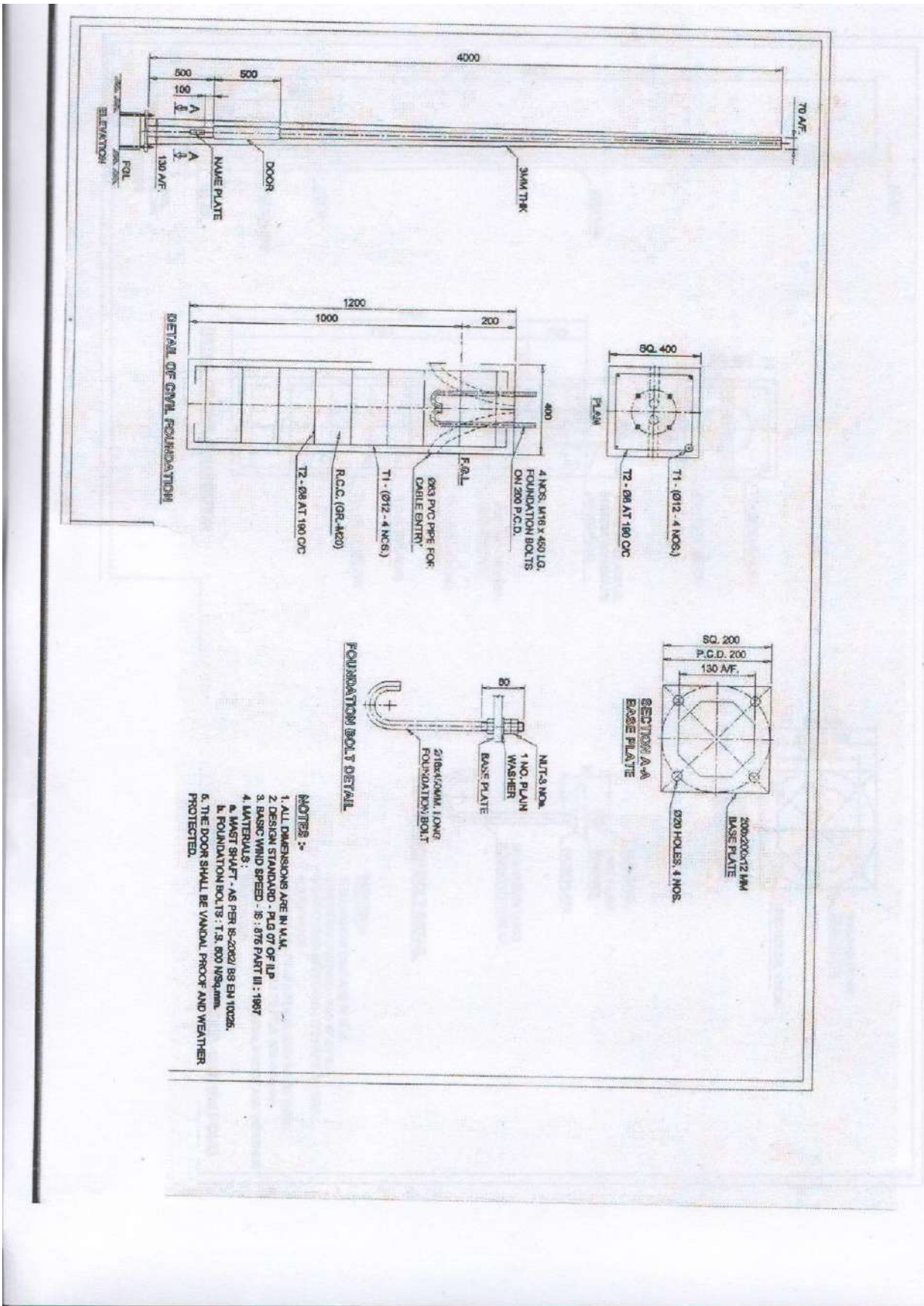

Detailed Drawing of 5m height octagonal pole.

(Annex-03)

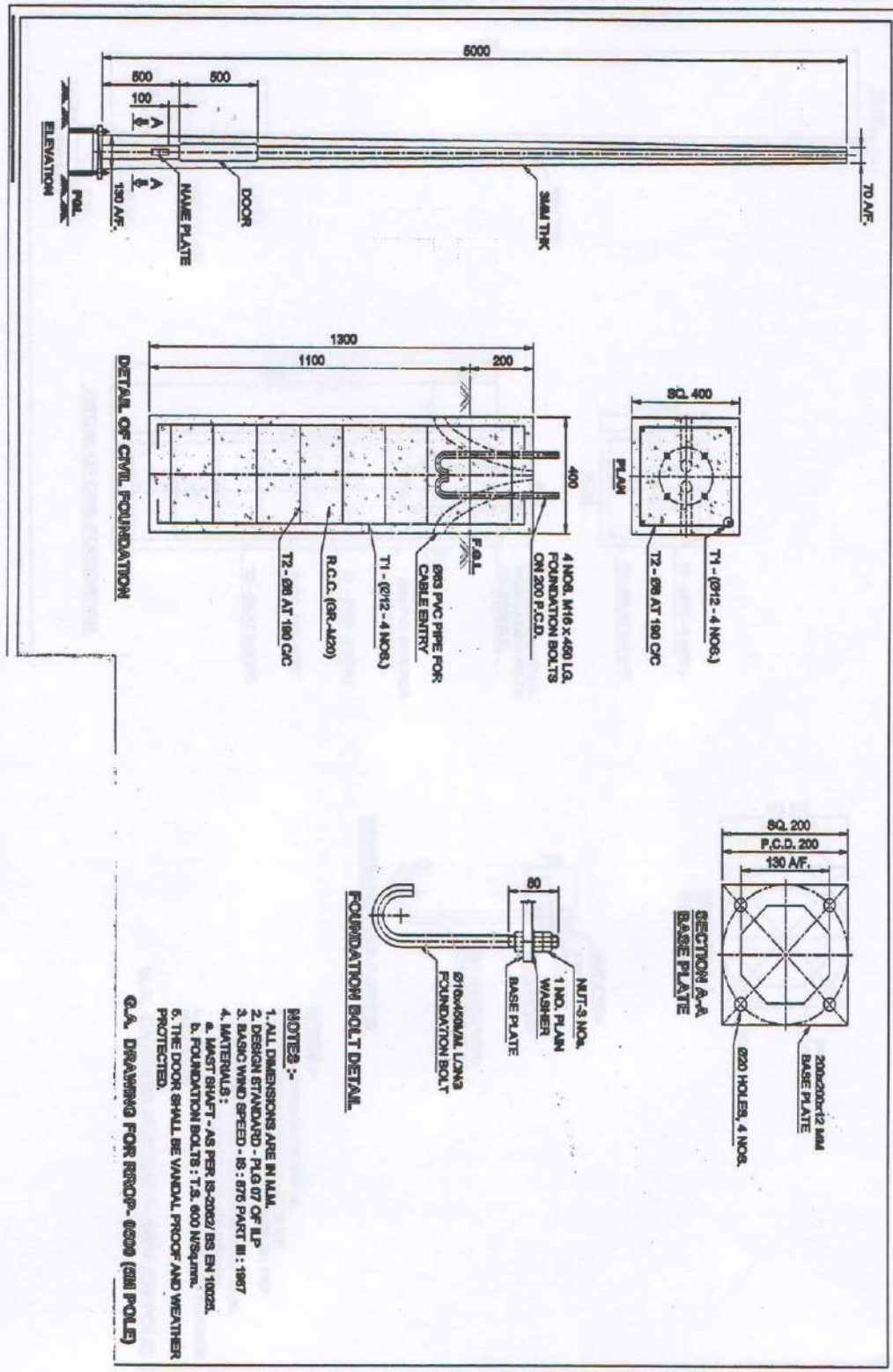

Detailed Drawing of 6m height octagonal pole.

(Annex-04)

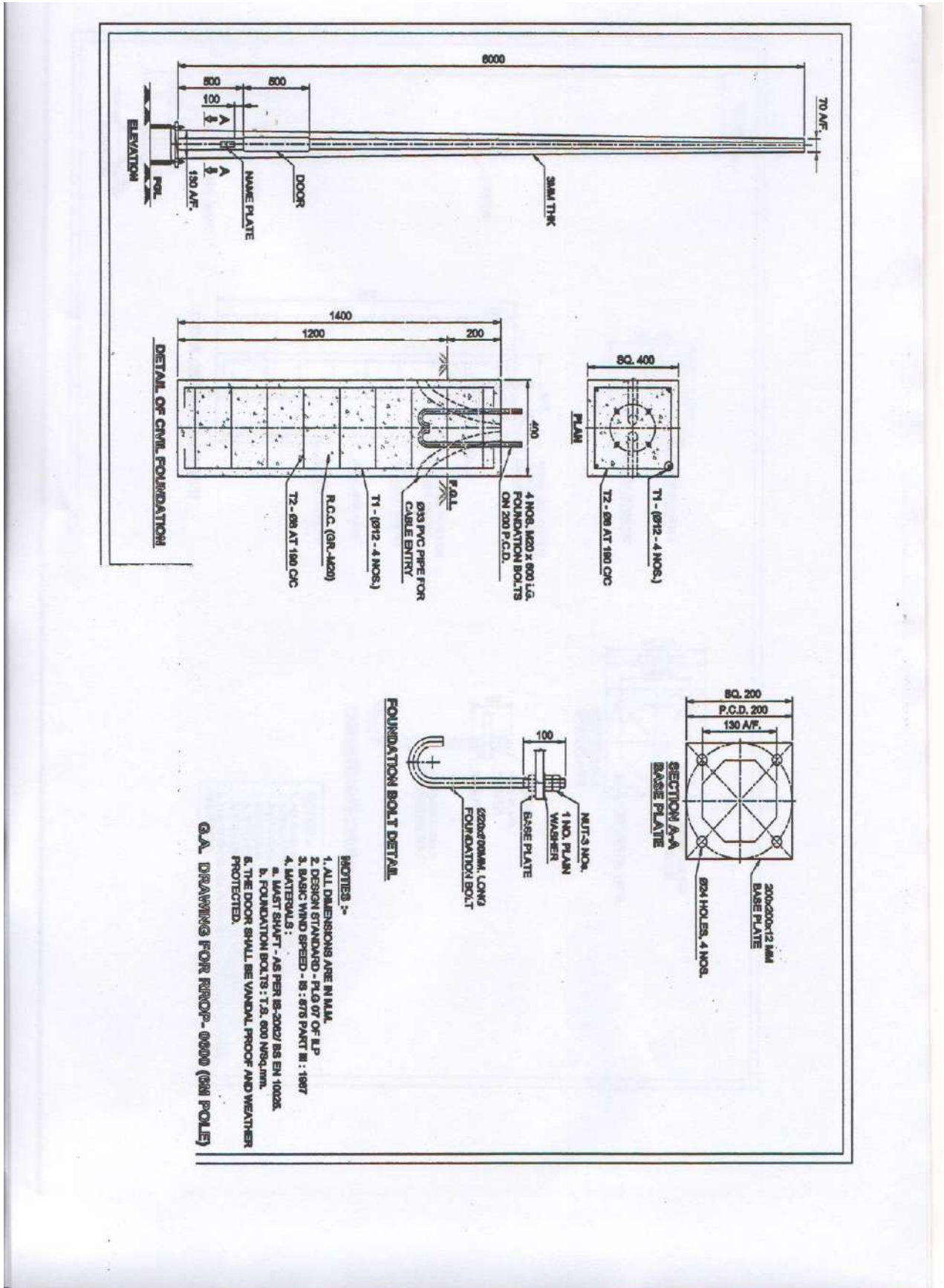

Detailed Drawing of 7m height octagonal pole.

(Annex-05)

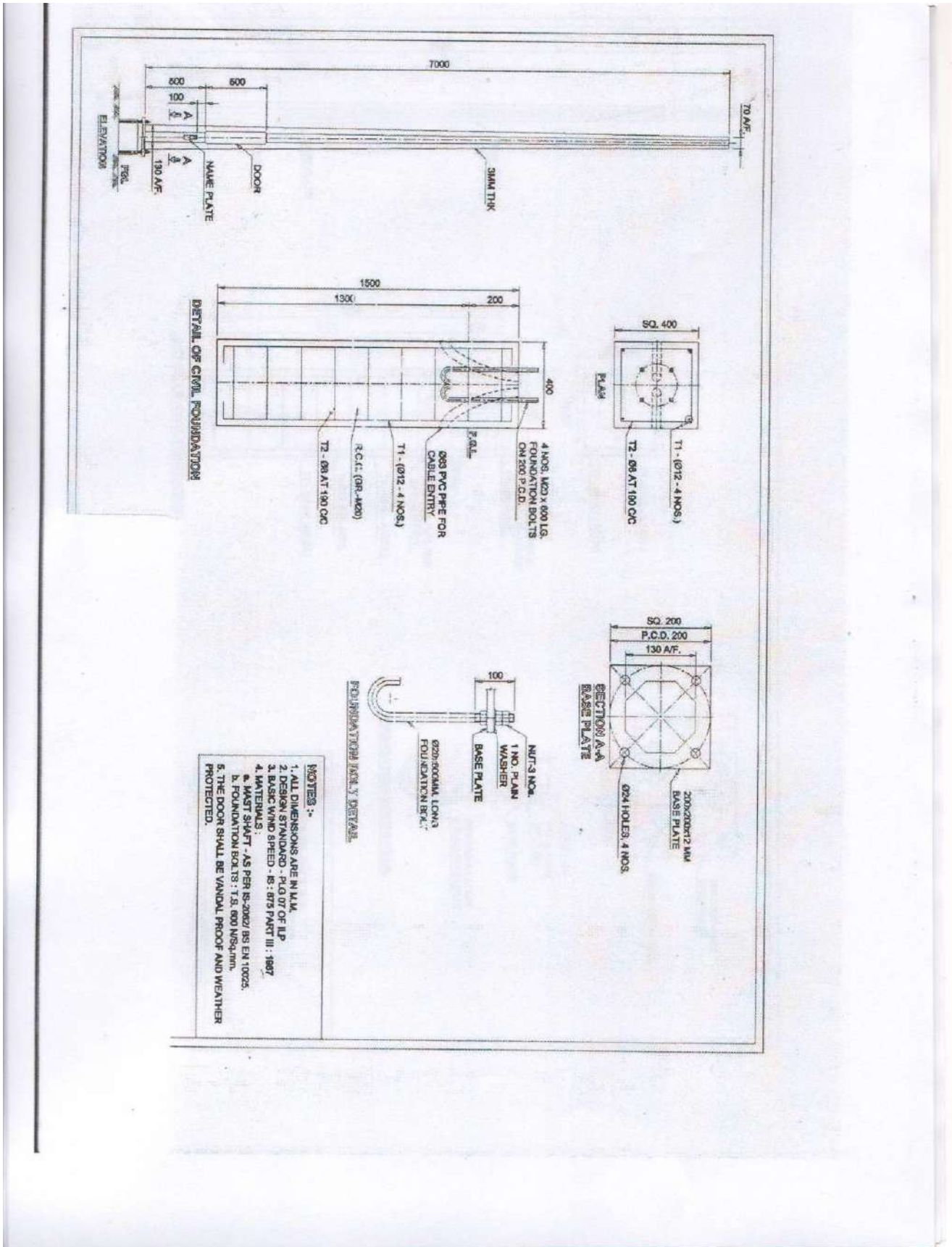

Detailed Drawing of 8m height octagonal pole.

(Annex-06)

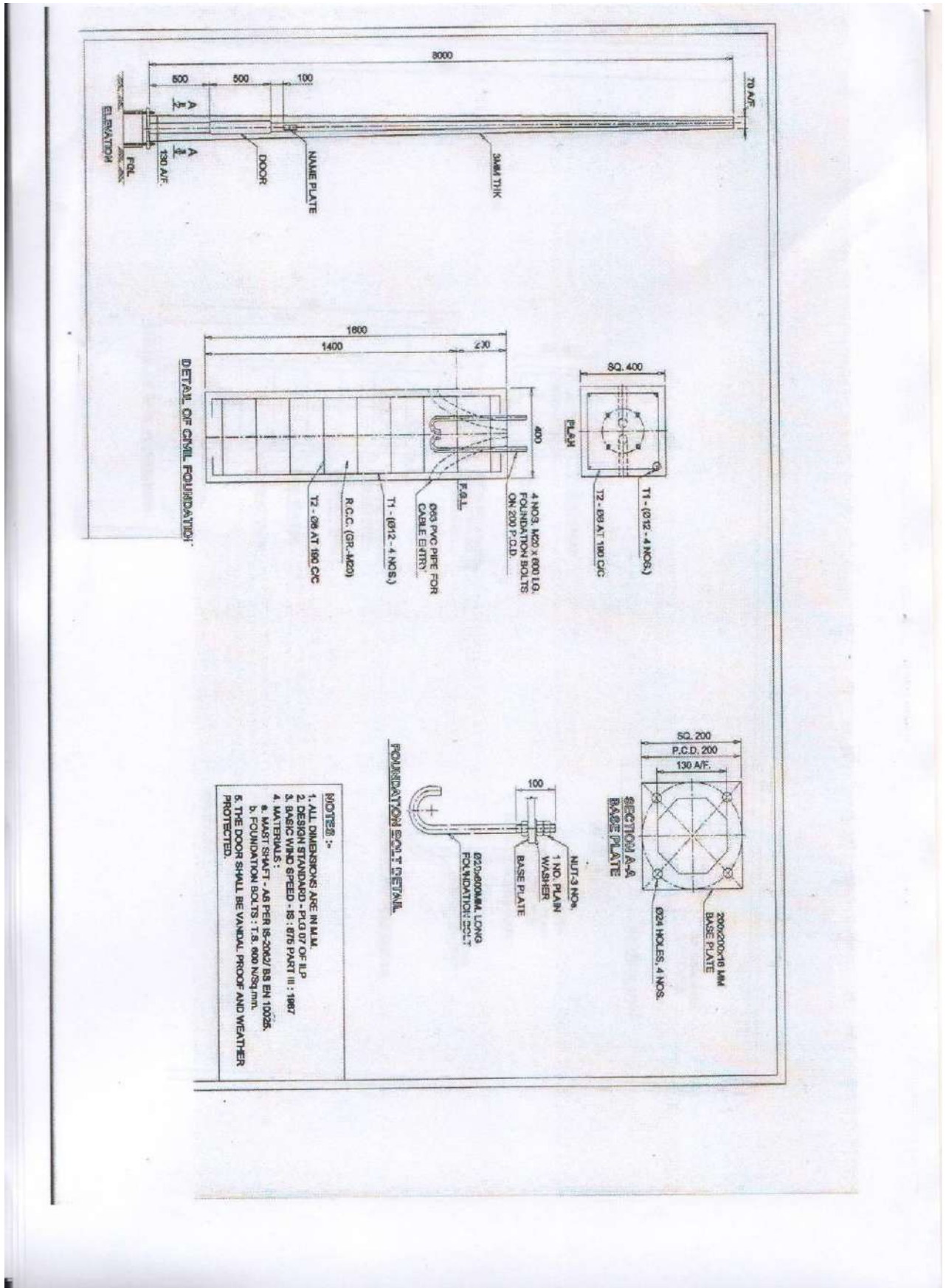

Detailed Drawing of 9m height octagonal pole.

(Annex-07)

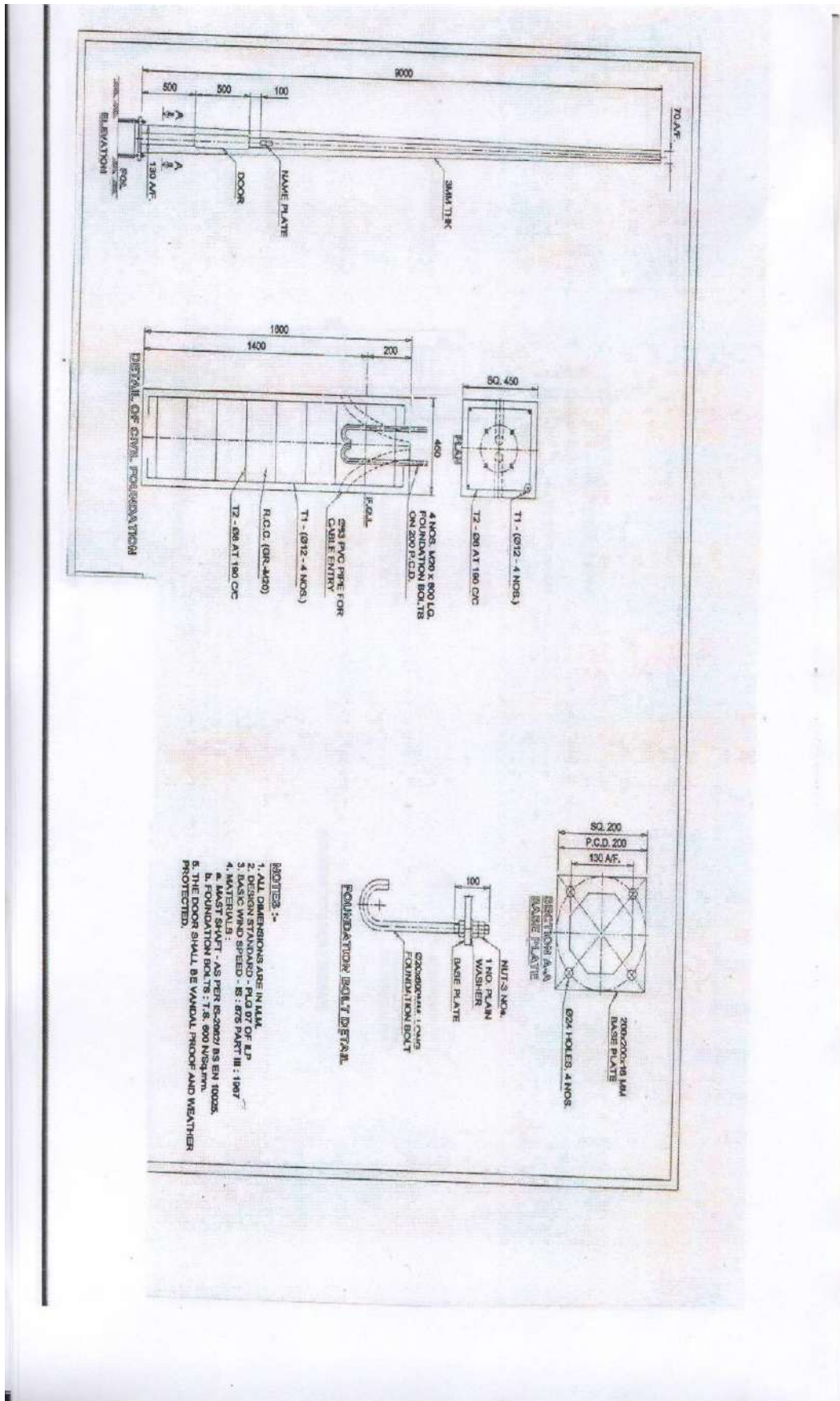

Detailed Drawing of 10m height octagonal pole

(Annex-08)

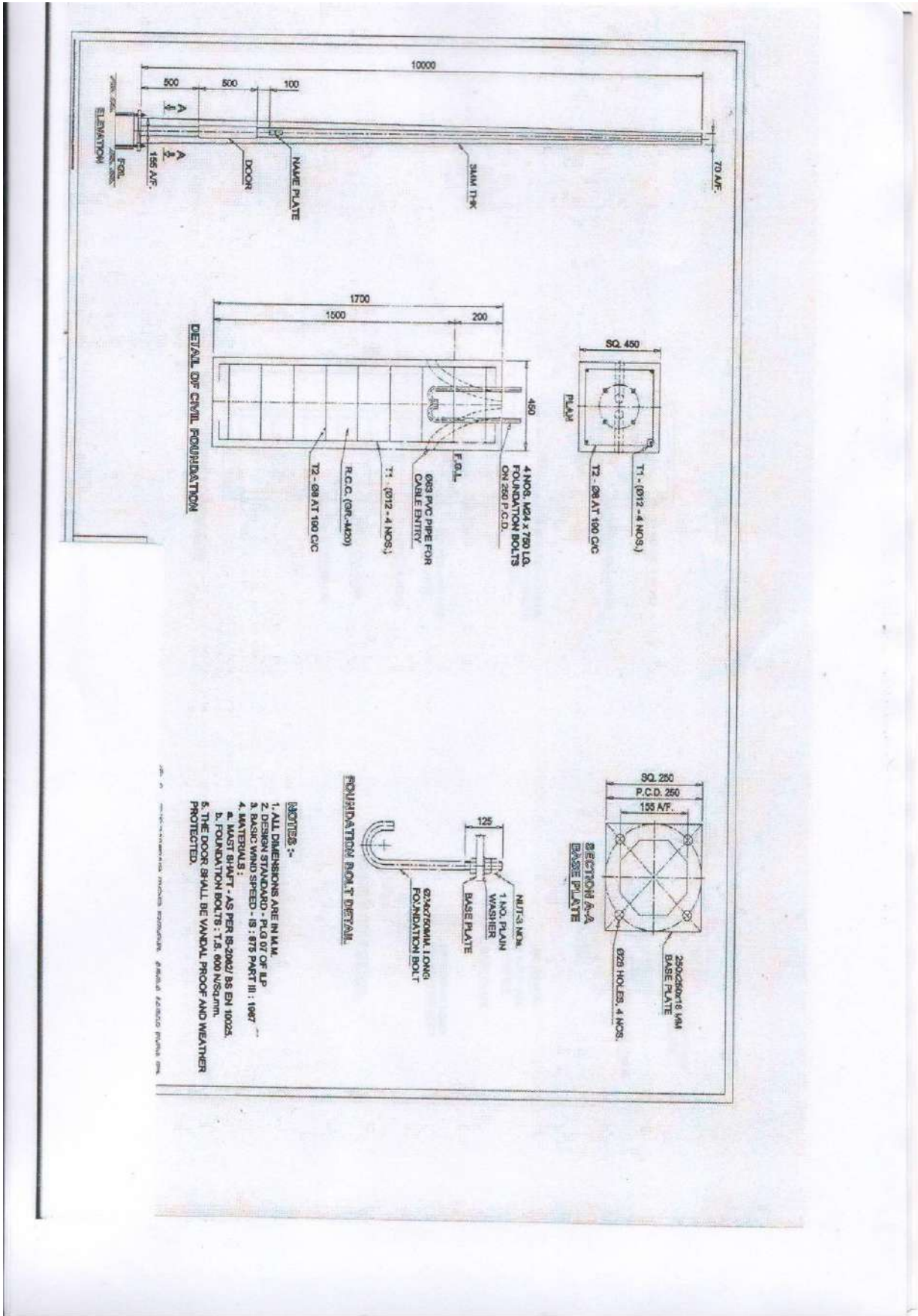

Detailed Drawing of 11m height octagonal pole.

(Annex-09)

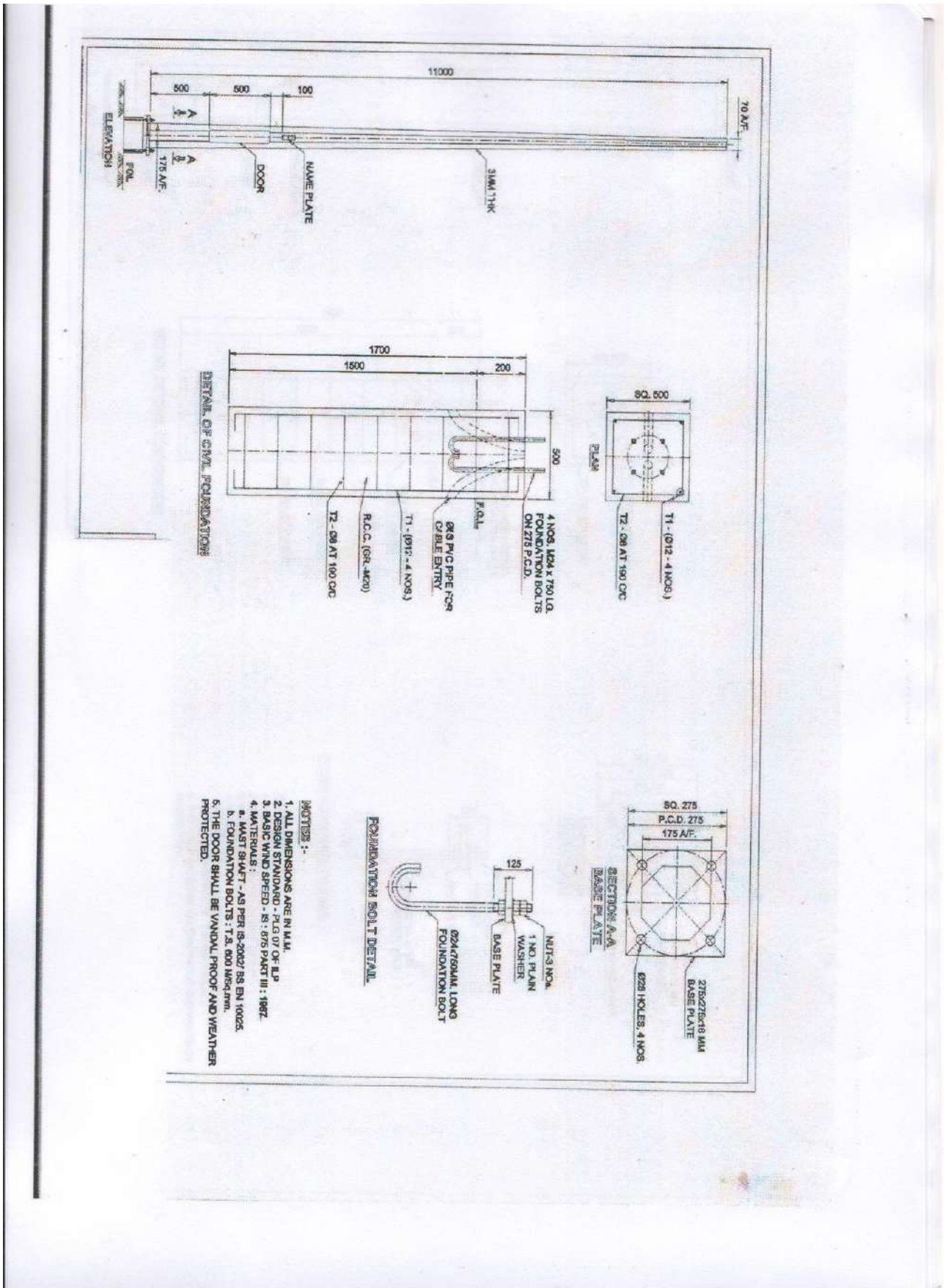

Detailed Drawing of 12m height octagonal pole.

(Annex-10)

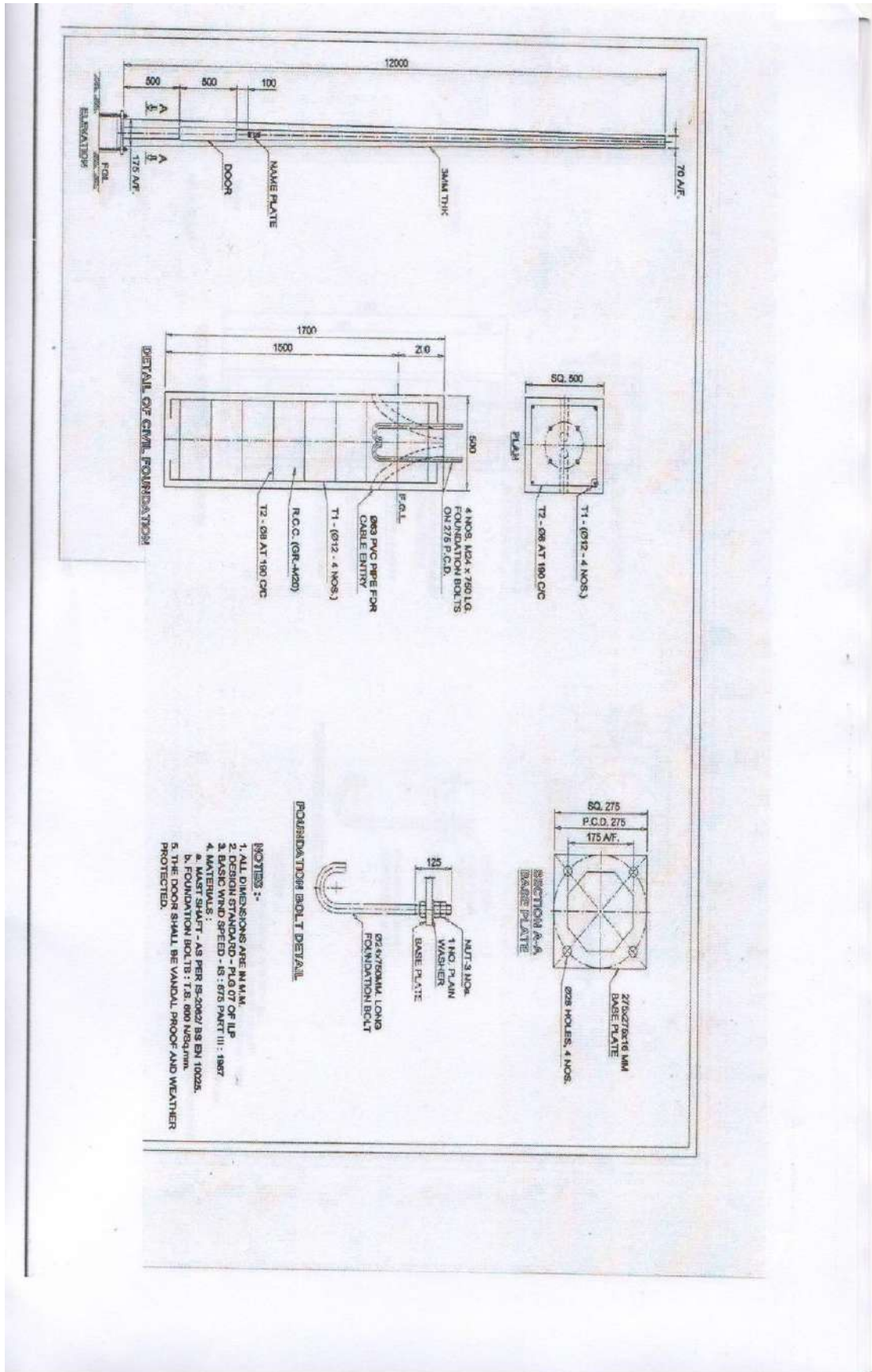

Detailed Drawing of ISI Mark MS Pole Height 5.7 Mtr

(Annex-11)

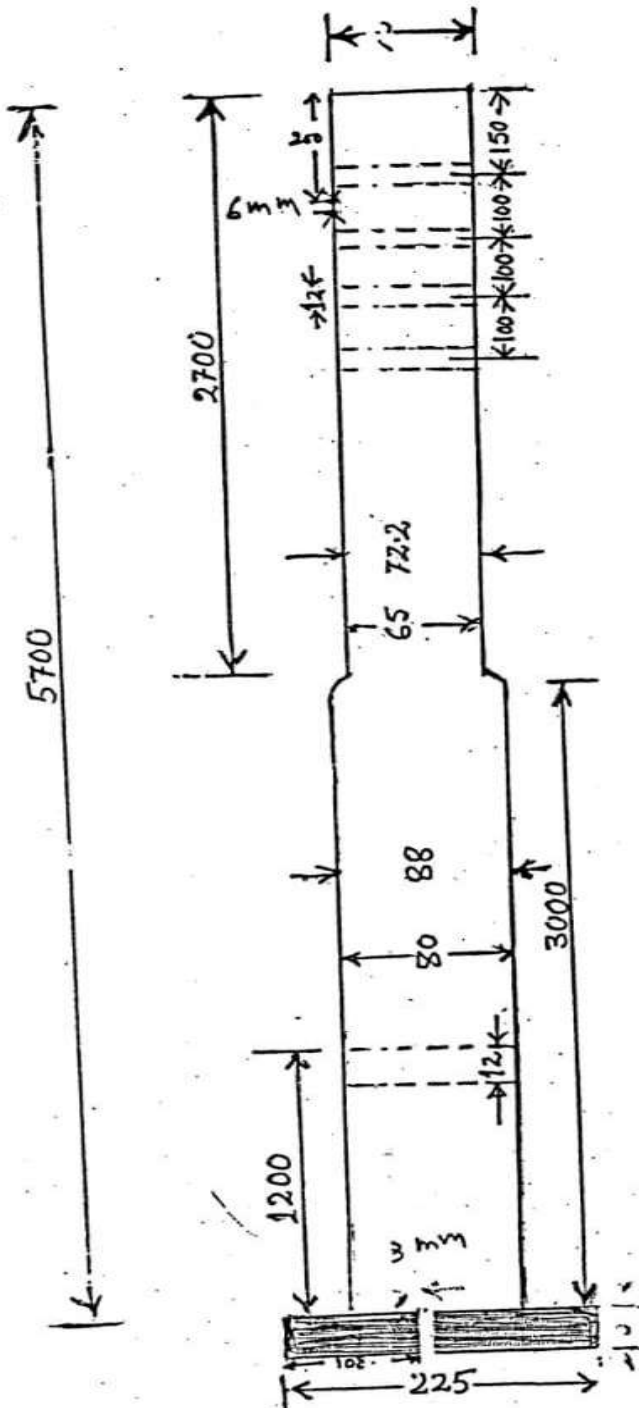

C.G. WATER SUPPLY & SEWERAGE DEPARTMENT
ENERGY DEVELOPMENT AGENCY
DRAWING NO- 01
DRAWN BY: CREDA
M.S. POLE

ALL DIMENSIONS ARE IN MM.
M.S. POLES

Detailed Drawing of ISI Mark GI Pole B class Height 5.7 Mtr (Annex-12)

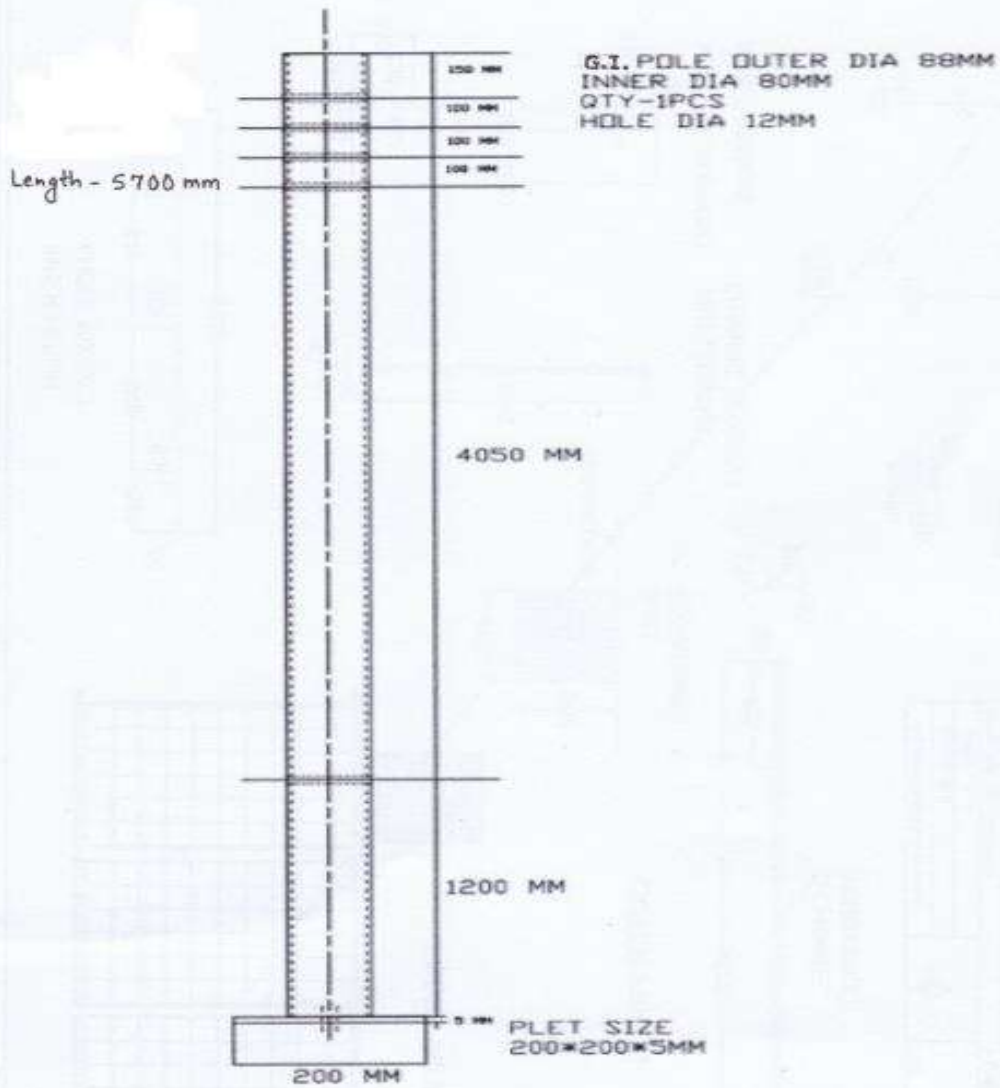

Galvanised Pole

Drawing of	Galvanised Pole (GI)
Agency	Chhattisgarh State Renewable Energy Development Agency (CREDA)

Drawing of ISI Mark G.I. Pole Street Light, Pedestrian Street Light, Special Pedestrian Light with Street Light Bracket, Height 4.5 Mtr, 6mtr, 9mtr Above ground level
(Annex-13)

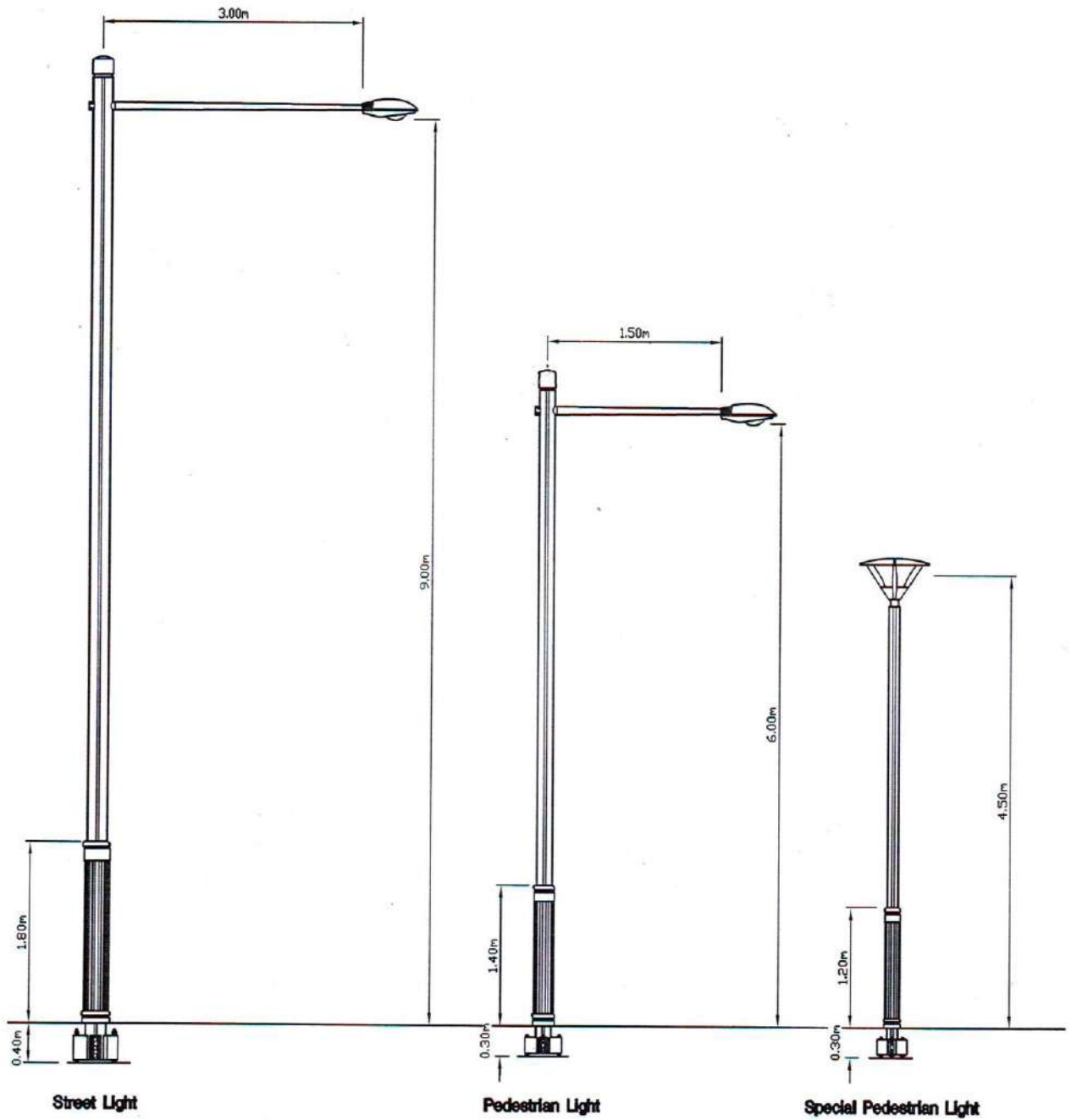

Detailed Drawing of G.I. Stay Set, Street Light Bracket, Pole, Cable Fixture (Annex-14)

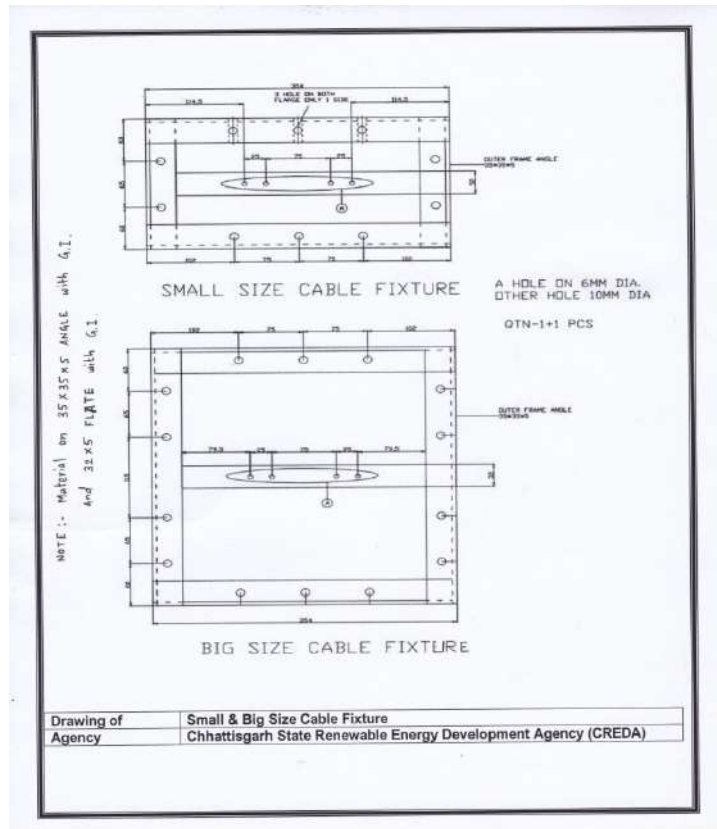
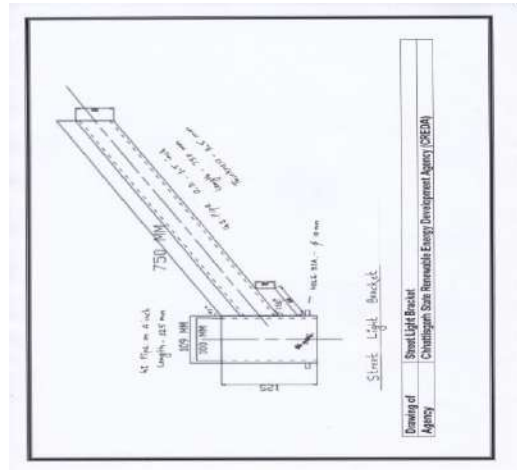
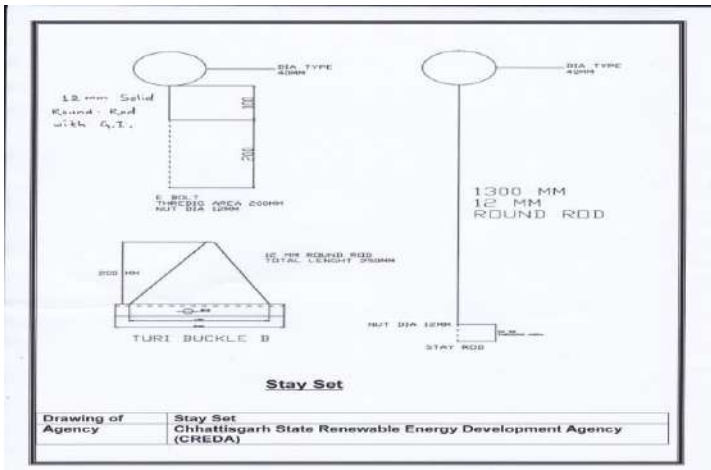

Detailed Drawing of G.I. Single arm bracket for octagonal Street Light pole of various height (Annex-15)

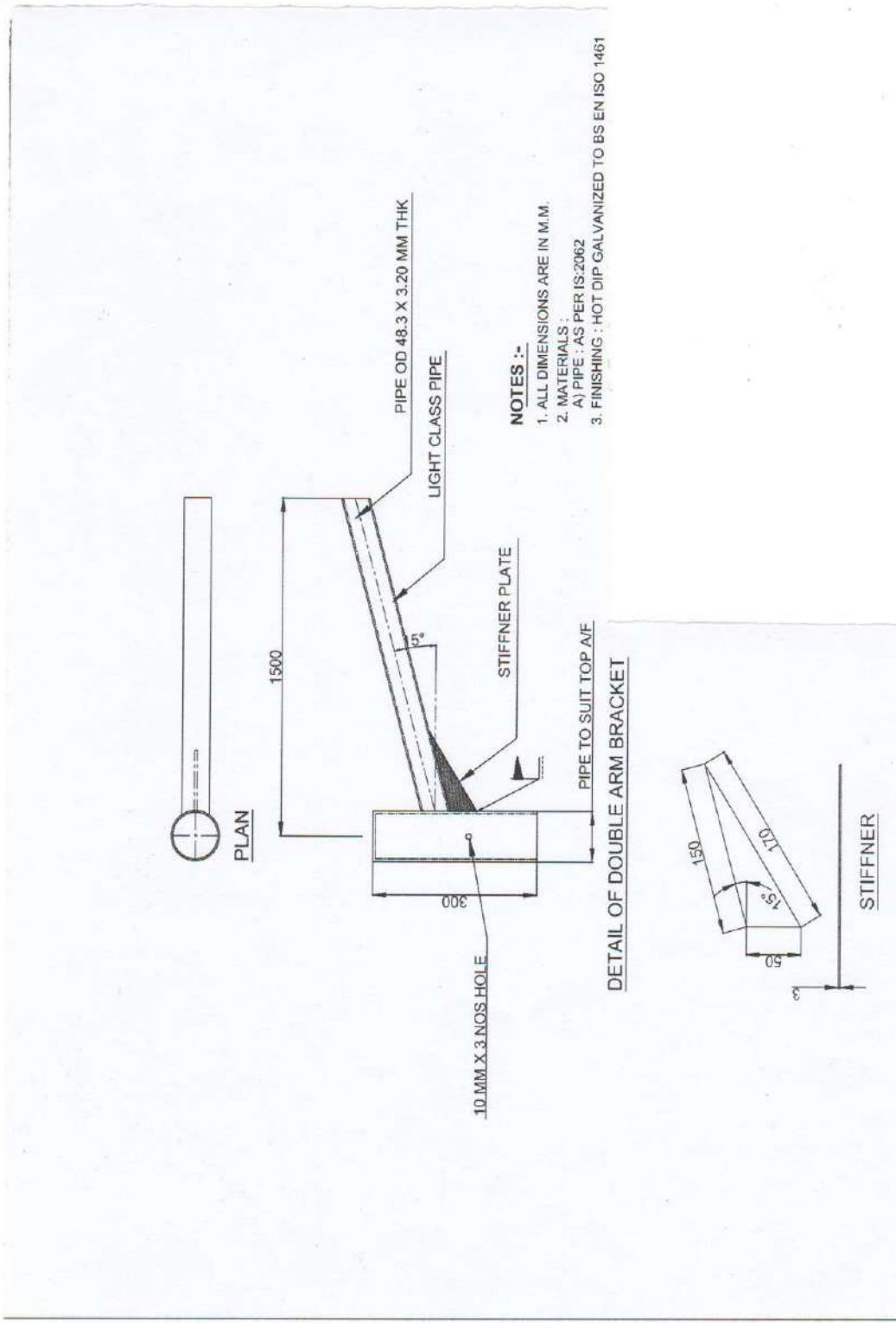

Detailed Drawing of G.I. Double arm bracket for octagonal Street Light pole of various height
 (Annex-16)

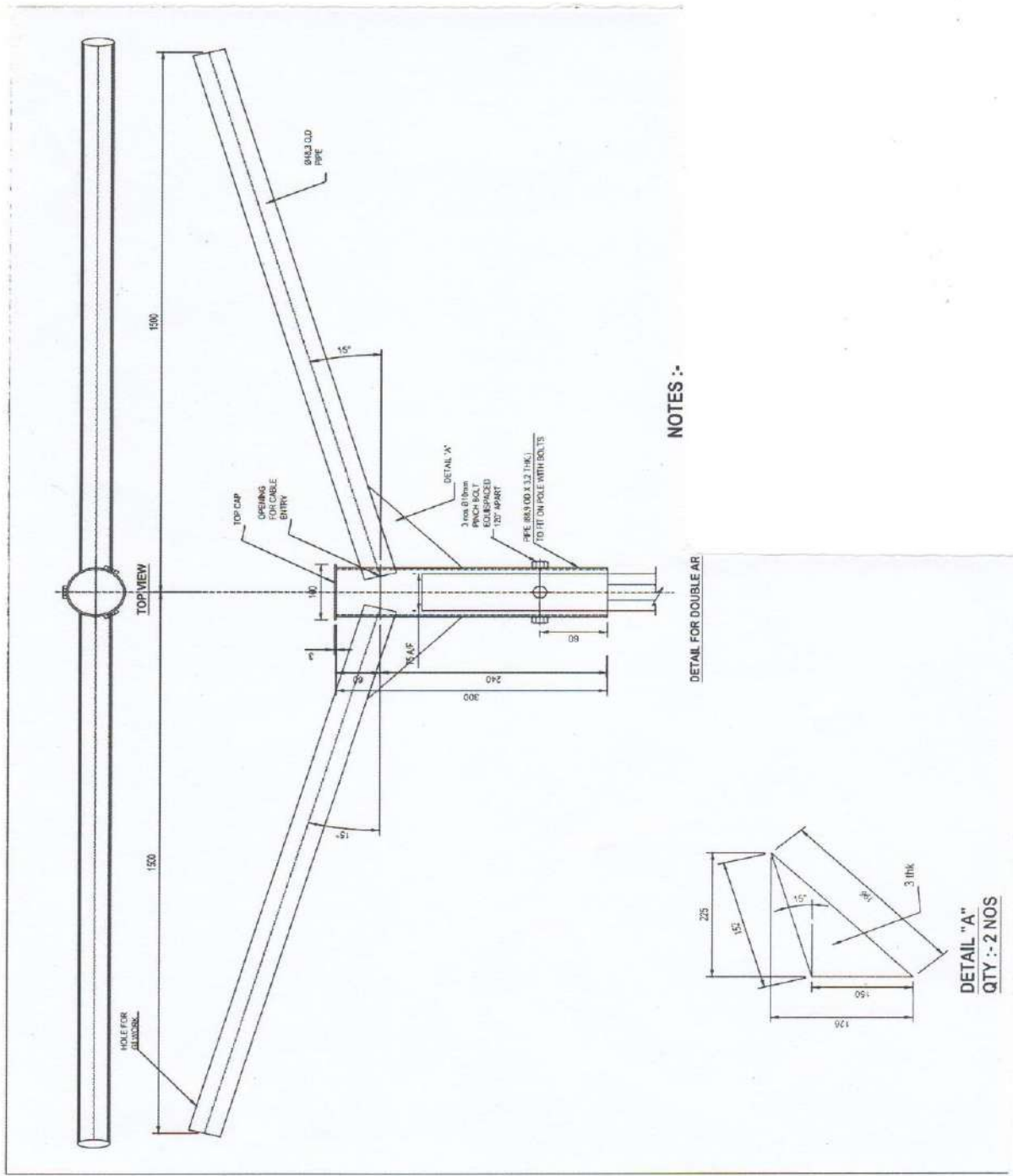

Annexure-17

Detailed Drawing and Technical Specification of Chain Link Fencing

Fabrication, supply and installation of fencing of 10 gauge chain link wire mesh of 75X75 mm opening, fitted with 50X50X6 mm vertical M.S. Angle at spacing of 2.5 mtr & 35X35X5 mm horizontal M.S. Support. Every set of fencing will have one M.S. Angle framed gate with same chain link wire mesh with locking arrangement and two extra posts. Three lane barbed bolts, washer and clip as per enclosed design drawing and specification with two coat steel primer zinc chromate and one coat silver/aluminium paint of standard brand with installation and fitting of fencing with grouting the poles in 1:2:4 P.C.C. of size 0.45X0.45X0.60 mtr. for given requirement with complete civil material.

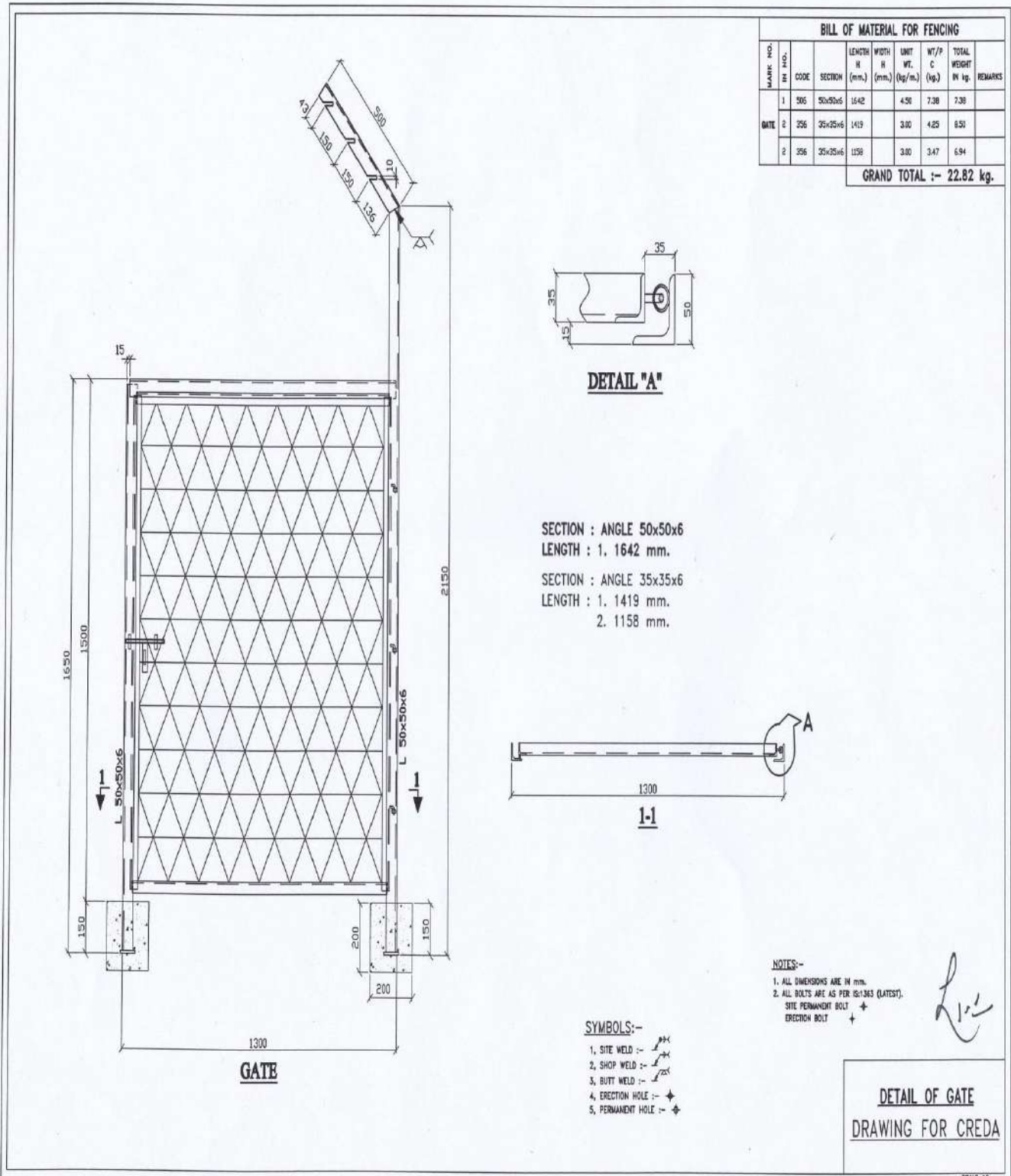

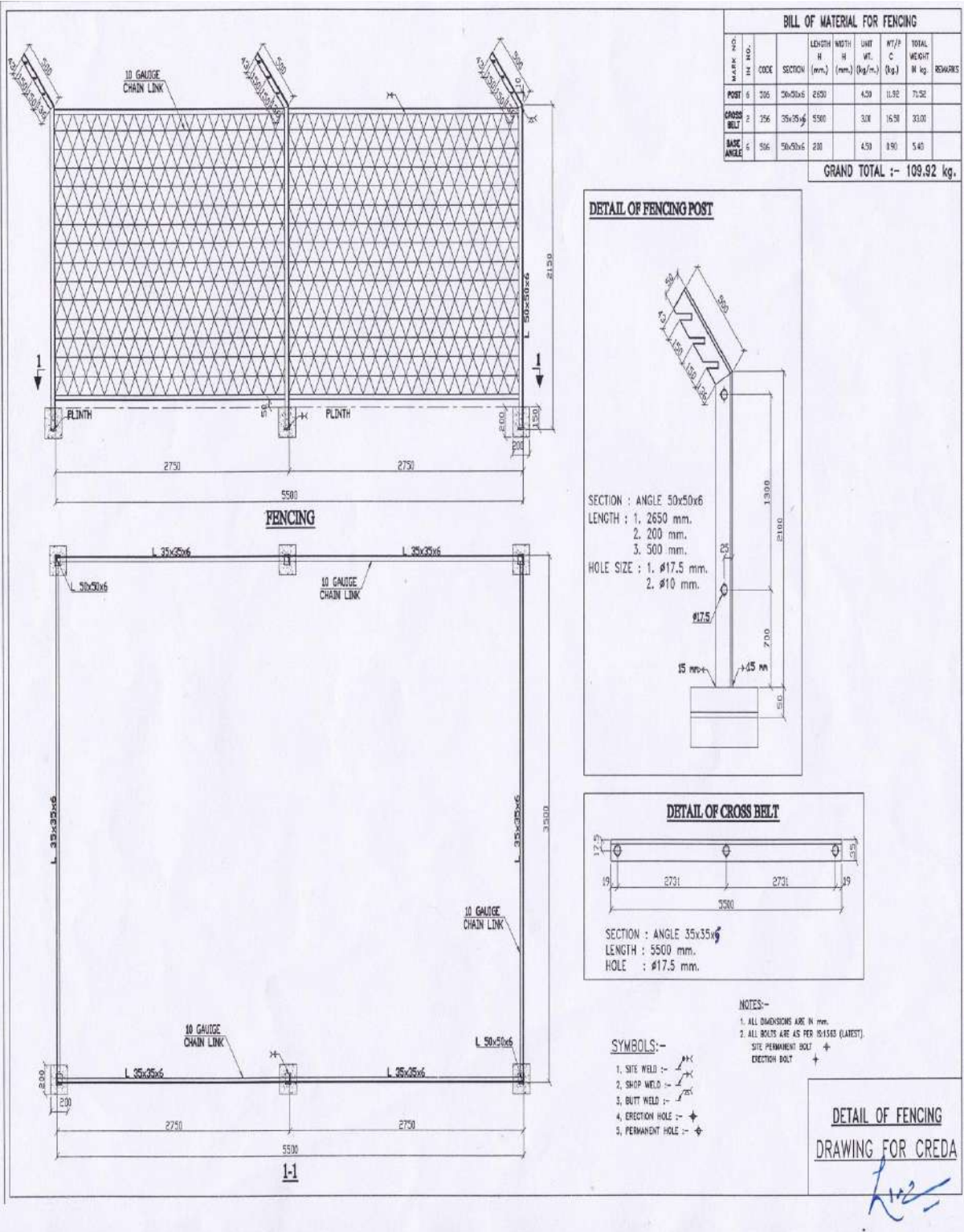

Section-04

1.Price Bid

(For supply of various fabrication items used in new work and other operation and maintenance work/New Project Work)

PRICE BID

Schedule of Rates for supply of Fabrication items

(e-bidding as per Specifications & Scope of Work of No.81347/CREDA/HOR/RE-V/PDN Fabrication/2021-22- Dated : 27.08.2021)

S. No	Item code	Description of Item	Unit	Rate (In Rs.) Exe. GST	GST as applicable
1	-	Supply of hot dipped galvanized (in single dip to average 80 micron) Octagonal pole made of 3mm thick steel plate having bases plate 200x200x12mm, Window and flush cover with hacking arrangement at height from base for cable termination block, pole suitably reinforced with welded steel section at window cut section to make the strength of pole unaffected, with 4 nos. 450 mm long, 16mm dia hot dipped GI foundation bolts (EN8 grade)			
1.1	A 1.1	3 Meter height Approx Min Weight 27 kg bare pole	Nos		
1.2	A 1.2	4 Meter height Approx Min Weight 35 kg bare pole	Nos		
1.3	A 1.3	5 Meter height Approx Min Weight 42 kg bare pole	Nos		
2	-	Supply of hot dipped galvanized (in single dip to average 80 micron) Octagonal pole made of 3mm thick steel plate having bases plate 200x200x12mm, Window and flush cover with hacking arrangement at height from base for cable termination block, pole suitably reinforced with welded steel section at window cut section to make the strength of pole unaffected, with 4 nos. 600 mm long, 20mm dia hot dipped GI foundation bolts (EN8 grade)			
2.1	A 2.1	6 Meter height Approx Min Weight 50 kg bare pole	Nos		
2.2	A 2.2	7 Meter height Approx Min Weight 57 kg bare pole	Nos		
3	-	Supply of hot dipped galvanized (in single dip to average 80 micron) Octagonal pole made of 3mm thick steel plate having bases plate 200x200x16mm, Window and flush cover with hacking arrangement at height from base for cable termination block, pole suitably reinforced with welded steel section at window cut section to make the strength of pole unaffected, with 4 nos. 600 mm long, 20mm dia hot dipped GI foundation bolts (EN8 grade)			
3.1	A 3.1	9 Meter height Approx Min Weight 84 kg bare pole	Nos		
4	-	Supply of hot dipped galvanized (in single dip to average 80 micron) Octagonal pole made of 3mm thick steel plate having bases plate 250x250x16mm, Window and flush cover with hacking arrangement at height from base for cable termination block, pole suitably reinforced with welded steel section at window cut section to make the strength of pole unaffected, with 4 nos. 750 mm long,			

		24mm dia hot dipped GI foundation bolts (EN8 grade)			
4.1	A 4.1	10 Meter height Approx Min Weight 101 kg bare pole	Nos		
5	-	Supply of hot dipped galvanized (in single dip to average 80 micron) Octagonal pole made of 3mm thick steel plate having bases plate 275x275x16mm, Window and flush cover with hacking arrangement at height from base for cable termination block, pole suitably reinforced with welded steel section at window cut section to make the strength of pole unaffected, with 4 nos. 750 mm long, 24mm dia hot dipped GI foundation bolts (EN8 grade)			
5.1	A 5.1	11 Meter height Approx Min Weight 133 kg bare pole	Nos		
5.2	A 5.2	12 Meter height Approx Min Weight 160 kg bare pole	Nos		
6	-	Fabrication and supply of M.S. Pole, with ISI "B" Class M.S. Pipe as per drawing and specification enclosed with all material and with two coat Zink Chromate primer and tow coat Silver/Aluminium Paint of standard brand 12" x 12" base plate (10 thickness) foundation in MS Pole with stiffener and 4 Nos. T-bolt with double nuts (20 mm. Dia & 900 mm. Length. Nut bolt arrangement in 4 feet from the bottom of pole.			
6.1	A 6.1	5.7 Meter Height Approx Min weight 40-42 kg bare pole	Nos		
6.2	A 6.2	7.5 Meter Height Approx Min Weight 80-82 kg bare pole	Nos		
7	-	Fabrication & Supply of ISI mark G.I .pipe poles made of "B" class making necessary hole for cable entry and providing earthing stud(Welded at specified height) as per specifications and drawing			
7.1	A 7.1	5.7 Meter Height Approx Min weight 45-48 kg bare pole	Nos		
7.2	A 7.2	7.5 Meter Height Approx Min weight 62-65 kg bare pole	Nos		
8	A 8	Fabrication and supply of ISI mark G.I. special type pedestrian pole as per drawing with 25 watt street light luminary warm LED (4.5 Mtr height) with PU painting as per CREDA requirement, Approx Min Weight -35-38kg including bracket	Nos		
9	A 9	Fabrication and supply of ISI mark G.I. pedestrian pole as per drawing with street light bracket with PU painting as per CREDA requirement (6 Mtr height),approx Min Weight 45-48 kg including bracket	Nos		
10	A 10	Fabrication and supply of ISI mark G.I. street light pole as per drawing with street light bracket (9 Mtr height) with PU painting ,Approx min weight -86-89kg including bracket	Nos		
11	A 11	Fabrication and supply of ISI mark G.I. cable fixtures Type A, hot dipped galvanized Min Weight:-4.5Kg	Nos		
12	A 12	Fabrication and supply of ISI mark G.I. cable fixtures Type B, hot dipped galvanized Min Weight:-3.0Kg	Nos		
13	A 13	Fabrication and Supply of ISI mark G.I .pipe "B" Class arrangement(850 mm length and 50 mm dia) for underground cabling in pole near foundation with suitable G.I. clamp for holding ISI mark G.I. pipe "B" Class	Nos.		

14	A 14	Fabrication & Supply of G.I. stay sets as per specifications and drawing	Nos.		
15	A 15	Fabrication & supply of ISI mark G.I. pipe "B" Class street light bracket for mounting Street Light fittings as per specifications and drawing. Approx Min weight 2.75-3.5kg	Nos.		
16	A 16	Fabrication & supply of ISI mark hot dipped G.I. Single arm street light bracket(Size OD 48.3x3.20 MM Thick, Length 1.5Mtr Centre to top with 15' inclination from horizontal plane) for mounting Street Light fittings in octagonal pole of various height as per specifications and drawing. Pipe Material IS:2062 (Min Approx weight 08 kg bare)	Nos.		
17	A 17	Fabrication & supply of ISI mark hot dipped G.I. Double arm street light bracket(Size OD 48.3x3.20 MM Thick, Length 1.5Mtr Centre to top with 15' inclination from horizontal plane) for mounting Street Light fittings in octagonal pole of various height as per specifications and drawing. Pipe Material IS:1161, YST:210Mpa (Min Approx 13 kg bare)	Nos.		
18	A 18	Fabrication & supply of ISI mark G.I. pipe "B" Class Wall Mount Brackets as per specifications and drawing	Nos.		
19	A 19	Fabrication and supply of hot dipped galvanised structure for mounting of solar modules or any other structure as per specification, size and design given with all required material, drilling work and two coat steel primer zinc chromate of standard quality	per Kg		
20	A 20	Fabrication and supply of fencing of 10 gauge chain link wire mesh of 75X75 mm opening, fitted with 50X50X5 mm vertical M.S. Angle at spacing of 2.5 mtr & 3 5X35X5 mm horizontal M.S. Support. Every set of fencing will have one M.S. Angle framed gate with same chain link wire mesh with locking arrangement and two extra posts. Three lane barbed bolts, washer and nut as per enclosed design drawing and specification with two coat steel primer zinc chromate silver/aluminium paint of standard brand with installation and fitting of fencing with grouting the poles in 1:2:4 P.C.C. of size 0.45X0.45X0.60 mtr. for given requirement with complete civil material	Per running meter (RMT)		

Certified that rates quoted above are as per the requirement, specifications, and terms & condition mentioned in the tender document. Above rates are FOR anywhere in the State of Chhattisgarh inclusive of roadworthy packing, loading, unloading, all types of incidental expenses, insurance, duties and any other job required to properly execute the work. The GST payable on the bill produced for payment to CREDA shall be paid in addition to above quoted price as per rate of GST applicable at the time of billing.

(No other cost will be claimed above the price quoted)

Note:- Partial bidding shall be not allowed. Bidder shall have to quote rates for all items.

Signature of Bidder

Name _____

Seal _____

Signature _____

2.DRAFT AGREEMENT (Annexure-18)

CONTRACT AGREEMENT BETWEEN Chief Engineer Chhattisgarh State Renewable Energy Development Agency (CREDA) Raipur AND M/s..... Represented by THIS CONTRACT AGREEMENT against BidNo.81347/CREDA/HOR/RE-V/PDN FAB /2021-22 Dated : 27.08.2021(also referred to as “Service Contract”) is made on the XXth day of _____2021.

BETWEEN

(1) Chief Engineer Chhattisgarh State Renewable Energy Development Agency (CREDA) Raipur a society incorporated under the laws Society Registration Act 1973 , (1973 , Sr. No. 44) (with amendment from time to time) and having its Registered Office at VIP Road Near Energy Education Park, Village- Fundhar, Raipur and (hereinafter called “The Employer” and also referred to as “CREDA”)

And

(2)Represented bya company incorporated under the laws of Companies Act 1956/2013/ Partnership firm/ Proprietorship firm/Consortium (as applicable, with amendment from time to time) and having its Principal place of business at.....and Registered Office at.....hereinafter called “The Contractor” and also referred to as “.....”

Whereas the contractor has offered to enter into contract with the said CREDA for the **“Standardization of rates for supply and installation of various fabrication items used in PDN works , PDN civil works for operation and maintenance/project works in CREDA anywhere in the state of Chhattisgarh”**.

Wide Bid No.81347/CREDA/HOR/RE-V/PDN-FAB /2021-22 Dated: 27.08.2021on the terms and conditions herein contained and the rates approved by the CREDA (Letter No. dated annexed here to) have been duly accepted and whereas the necessary security deposit shall be furnished in accordance with the provisions of the Bid document and whereas no interest will be claimed on the security deposits.

Now these presents witness and it is hereby agreed and declared by and between parties to these presents as follows -

- 1) The Contractor shall, during the period of this contract, that is to say from to or completion thereof, until this Contract shall be determined by such notice as is hereinafter mentioned, safely carryout, by means of labours employed at his own expenses and by means of tools, implements and equipment etc. to be supplied by him to his labour at his own expenses, for supply of **“supply and installation of various fabrication items used in PDN works ”** as described in Bid documents. (Annexed to the agreement).
- 2) The NIT (Notice Inviting Bid), Corrigendum to NIT, Notices, Bid documents (Qualifying, Technical and Financial), approved rates annexed hereto and such other additional particulars, undertaking, instructions, general conditions of contract, Scope of work, Technical specifications of items/works and Annexures therein, engineering documents, detailed specifications of BOS , so far they relate to the Bid 81347/CREDA/HOR/RE-V/PDN FAB /2021-22 Dated : 27.08.2021as may be found requisite to be given during execution of the work shall be deemed and taken to be an integral part of the contract and shall also be deemed to be included in the expression "The Agreement or "The Contract "wherever herein used.
- 3) The contractor shall also supply the requisite number of workmen with means & materials as well as tools, appliances, machines, implements, vehicles for transportation, cartage etc. required for the proper execution of work within the time prescribed in the work orders and /or as per the Bid conditions.

- 4) The Engineer in Charge or his authorized representative (s) shall be entitled at all reasonable times to inspect and supervise and test during commissioning. Such inspection will not relieve the eligible bidder from their obligations under this contract.
- 5) Material can be inspected before dispatch or in transit by the authorized representatives of CREDA at the factory at the cost of the eligible bidder, if desired by CREDA. CREDA reserves right to inspect the material at Godowns / Temporary Stores before dispatch and also at works sites.
- 6) CREDA shall deduct TDS for Income Tax, applicable cess on Civil Work etc. under various acts and deposited with the appropriate authority. Costs and taxes before execution of agreement with CREDA so as to ensure tax deposition as per Government Rules accordingly.

7) ELIGIBLE BIDDER'S DEFAULT LIABILITY -

CREDA may by written notice of default to the eligible bidder, terminate the contract in circumstances detailed hereunder -

- (a) If in the opinion of the CREDA, the eligible bidder fails to complete the supply/work within the time specified in the supply/work Order or within the period for which extension has been granted by CREDA to the eligible bidder.
- (b) If in the opinion of CREDA, the eligible bidder fails to comply with any of the provisions of this contract.
- (c) In the event of CREDA terminating the contract in whole or in part as provided in paragraph (a) above, CREDA reserves the right to engage another eligible bidder or agency upon such terms and in such a manner as it may deem appropriate and the eligible bidder shall be liable to CREDA for any additional costs or any losses caused to CREDA as may be required for the supply of Items and or for penalty as defined under this Bid document until such reasonable time as may be required for the final completion of the work.
- (d) In the event CREDA does not terminate the contract as provided in paragraph (a) the eligible bidder shall continue performance of the contract, in which case he shall be liable to CREDA for penalty for delay as set out in this Bid document until the work is completed.

8) FORCE MAJEURE -

The eligible bidder shall not be liable for any penalty for delay or for failure to perform the contract for reasons of FORCE MAJEURE such as of God, acts of public, enemy, LWE problems, acts of government, cyclone, fires, floods, epidemics, quarantine restrictions, strikes, freight embargoes provided that if SI shall submit delay notice with appropriate cause of delay to the CREDA in writing within **15 days** of force majeure. CREDA shall verify the facts and may grant such extension as facts justify. Delay in supply of any accessories of Items etc. by the related vendors, to whom the Bidder has placed order, shall also not be treated as force majeure.

9) REJECTION OF WORKS -

In the event of any of the material supplied/work done by the eligible bidder is found defective in material or workman ship or otherwise not in conformity with the requirements of this contract specifications, CREDA shall either reject the material and/or work and advise the eligible bidder to rectify the same. CREDA may impose penalty for such rejection up to the 200% cost of the entire system. Habitual/repeated offenders shall be black listed/debarred to participate in the any Bid/ Activity of CREDA till further orders. The eligible bidder on receipt of such notices shall rectify or replace the defective material and rectify the work free of cost. If the eligible bidder fails to do so CREDA may -

- a) At its option replace or rectify such defective materials and/or work and recover the extra cost so involved from the eligible bidder plus **15%** service charges of the cost of such rectification, from the eligible bidder and/ or terminate the contract for balance work/ supplies with enforcement of penalty as stated above.
- b) Defective materials/workmanship will not be accepted under any conditions and shall be rejected outright without compensation. The eligible bidder shall be liable for any loss/damage sustained by CREDA due to defective work **with enforcement of penalty as stated above.**

10) EXTENSION OF THE TIME -

If the completion of installation is delayed due to any reason beyond the control of the eligible bidder, the eligible bidder shall without delay give notice to the CREDA in writing of his claim for an extension of time. CREDA on receipt of such notice may or may not agree to extend the contract/delivery/completion date of the items/works as may be reasonable but without prejudice to other terms and conditions of the contract.

11) PENALTY FOR DELAY IN COMPLETION OF CONTRACT -

If the eligible bidder fails to complete the assigned work within the schedule time specified in the sanction order or any extension granted there to, CREDA will recover from the bidder as penalty a sum of half percent (0.5%) of the system price excluding GST/Tax for every delayed system per week. For this purpose, the date of taking over shall be reckoned as the date of completion. The total penalty shall not exceed 5% (Five Percent) of the cost.

However, imposition of such penalty shall be discretion of CREDA. This penalty may be decrease, increase or waved off due to various justified reasons on ground with recommendations of field staff on record. Period declared as lockdown or local quarantine /containment zones due to Covid-19 pandemic shall be waived off for the purpose of penalty.

Review of the progress of supply of the fabrication items used in PDN works allocated to bidders shall be done time to time by CREDA and if the progress of supply of fabrication items used in PDN works is found unsatisfactory, the allocation of entire remaining supply or their part of can be re-allocated to other bidders as per discretion of CREDA.

12) PENALTY DUE FROM THE ELIGIBLE BIDDER-

All costs of damages and delays for which the eligible bidder is liable to the CREDA will be deducted from any money due to the eligible bidder including the security deposit of any project under CREDA.

13) ELIGIBLE SI'S RESPONSIBILITY -

Notwithstanding anything mentioned in the specifications of subsequent approval or acceptance of the items/works by CREDA, if any, the ultimate responsibility for satisfactory performance of the entrusted work shall rest with the eligible bidder. If in any case the eligible bidder does not complete the work as per the Work Orders issued to them then CREDA may take over the task & complete the project at the risk and cost of eligible bidder.

14) RESPONSIBILITY TO RECTIFY THE LOSS AND DAMAGE -

If any loss or damage occurs to the work or any part thereof or materials/plant/equipment's for incorporation therein the period for which the eligible bidder is responsible for the cause thereof or from any cause whatsoever, the eligible bidder shall at his own cost rectify/replace such loss or damage, so that the permanent work confirms in every respect with the provision of the contract to the satisfaction of the Engineer. The eligible bidder shall also be liable for any loss or damage to the work/equipment's occasioned by him in course of any operation carried out to him during performing the contract.

15) RESPONSIBILITY TOWARDS THE WORKMAN OR OUT SIDERS -

- The eligible bidder shall have to take insurance coverage from any authorized Insurance Company against Workmen compensation due under Workmen Compensation Act and submit copy of the insurance document before issuance of Work Order.
- The eligible bidder shall ensure all safety measures during execution and repairs of the work. CREDA, will, in no case be responsible for any accident fatal or non-fatal, caused to any workman or outsider in course of transport or execution or repairs of work.

- All the expenditure including treatment or compensation will be entirely borne by the eligible bidders. The eligible bidder shall also be responsible for any claims of the workers including PF, Gratuity, ESI & other legal obligations.
 - Bidder shall have to submit JCCs within **60 days** after supply of Items in District Office of CREDA.
- 16)** Contractor shall provide 01 years' warranty in supplied items and 01 years warranty in works from the date of supply as per the terms & conditions prescribed in the Bid No 81347/CREDA/HOR/RE-V/PDN FAB /2021-22 Dated : 27.08.2021)
- 17) **DECLARATION OF CONFLICT OF INTEREST –****
- A.** The bidder shall not be permitted to Bid for the work if the section of HO CREDA (responsible for implementation of work) in which his near relative is posted. Furthermore, successful bidder shall not be given work in the district in which his near relative is posted. Bidder shall also intimate the names of his near relatives working in the CREDA. Bidder shall also intimate the name of persons who are working with him in any capacity and who are near relatives to any employee in CREDA. Any breach of this condition by bidder would render himself liable to be blacklisted for three years and removed from approved list of bidder.
- Note:-** By the term near relatives is meant Wife, Husband, Parents and son , Brother, Sister, Brother-in-law, Father-in-law, Mother-in-law etc.
- B.** Bidder must produce an affidavit (Annexure-20) stating the names of retired/removed employee of CREDA (if any) in his employment who retired /removed within last two years, if in case there is no such person in his employment, his affidavit should clearly state this fact. This affidavit is mandatory, if it is not produced along with the bid, the bid shall be rejected.
- 18)** (a) The contractor shall arrange insurance coverage for the materials and Items/works at his/ for the supply under execution and successful commissioning and subsequent handover to the CREDA. The contractor shall take up insurance or such other measures for the manpower so as to cover the claim for damage arising under workmen's compensation Act and other applicable State/ Central laws. CREDA shall not bear any responsibility on this account.
- (b) Bidder shall arrange for insurance coverage for Items during warranty. Insurance should cover for damage and theft. In case of such incidence, bidder must replace the lost/damaged part within 7 days.
- 19)** The bidder shall abide by the terms and conditions, rules, guidelines, construction practices, safety precautions etc. stipulated in the Bid document including any correspondence between the bidder and the **CREDA** having bearing on execution of supply/works and payments of supply/works to be done under the contract.
- 20)** The Bidder shall be responsible to follow all the laws including Workmen Compensation Act and all other laws in force & shall be responsible for all the obligations towards labour including EPF, ESI, etc.
- 21)** All the taxes deductible at source as per Acts in vogue shall be recovered by **CREDA** and deposited with the appropriate authorities
- 22)** Contractor agrees to abide by any decision/instruction passed by the appropriate authority under Anti-profiteering rules notified by the state/central government under GST act.
- 23)** Any dispute arising out of the contract shall be subject to the jurisdiction of Hon'ble High Court of Chhattisgarh.

I/We hereby state that we have provided information of our near relatives as stated in the affidavit attached at “Annexure – 03”.

"Herewith everything and anything contained in Bid document no.81347/CREDA/HOR/RE-V/PDN FAB /2021-22 Dated : 27.08.2021is part of this agreement which has been dully signed by both bidder and authorised signatory of CREDA".

In witness whereof the parties present today has hereby entered into agreement.

Signed & sealed on behalf of the above

Named contractor

Name :

Designation :

Signed on behalf of CREDA

Name: **Sanjeev Jain**

Designation: **Chief Engineer(RE-V)**

Witness:

1.Name:-.....

2. Name:.....

Address:-.....
.....

Address:-
.....

3.SCHEDULE - I

PART 'A': GENERAL INFORMATION

(Strike off whichever is not applicable. Separate sheets should be used, wherever necessary)

- 01. Name & Address of the Bidder :
- 02. Name & Address of the firm/Company etc. :
 - a) Registered office :
 - b) Factory/works address :
 - c) Fax Nos. :
 - d) Telephone / Mobile Nos. :
 - e) Email id :
- 03. Confirm whether Bidder is Manufacturer : Yes/No
- 04. Only manufacturer to give following particulars
 - a) Address of factory :
 - b) Year of starting manufacture :
 - c) Whether same/similar materials Manufactured earlier (if yes, give reference) :
 - d) Yearly/monthly production capacity :
 - e) Maximum yearly production Achieved so far :
- 05. Whether the firm is SSI Unit of Chhattisgarh State: Yes/No
 - a) If yes, write registration No. :
 - b) Whether documentary evidence Regarding registration enclosed :
 - c) Items for registration :
 - d) Period of registration :
 - d) Whether latest copy Competency/ Certificate furnished : Yes/No
- 06. Whether the firm is 100% owned by
 - a) State Government : Yes/No
 - b) Central Government : Yes/No
 - If yes, Notification/certificate issued from The competent authority to this effect is Enclosed : Yes/No
- 07. a) Whether the bidder is old participant with CREDA : Yes/No
 - b) If yes, whether documentary Evidence is enclosed. : Yes/No
- 08. Any other information that bidder may like to give in order to highlight his bid : If yes, give details

PLACE :

SIGNATURE OF BIDDER

NAME IN FULL

DATE :

DESIGNATION/STATUS

FIRM/COMPANY SEAL

4.SCHEDULE - II

PART 'B' : COMMERCIAL INFORMATION

(Strike off, whichever is not applicable. Separate sheets should be used. Wherever necessary)

- 01.i) Earnest Money Details : Bank draft/Bankers cheque payable to "CREDA", Raipur
- ii) Amount of E.M.D. & full details : `
- iii) If exempted, state whether the bidder / Fully Owned State/Central Govt. Unit : SSI Unit of C.G.
- iv) Reference of documentary evidence regarding exemption enclosed. : Yes/No
- 02. Whether the offer is valid for 6 months from the date of opening of commercial/technical bid. : Yes/No
- 03. Rate of Sales Tax on the date of bid (exclusive in the rate quoted) :
- 04. **DISCOUNT:**
 - a) Whether any rebate/discount is offered. : Yes/No
 - b) If yes, whether the rebate is unconditional/conditional : Yes/No
Rate/amount of rebate/discount
 - c) If conditional State condition : Yes/No
- 05. **PAYMENT TERMS:**
Whether CREDA's terms of payment is acceptable to Bidder : Yes/No
- 06. **COMPLETION PERIOD OF WORK:**
Whether Bidder is agreeing for completion period of work as Specified in the Bid : Yes/No
- 07. **PENALTY CLAUSE:**
Whether agreeable to CREDA's Penalty Clause : Yes/No
- 08. Whether agreeable to CREDA's clause of warrantee period : Yes/No
- 09. **SECURITY DEPOSIT:**
Whether Security Deposit clause is understood : Yes/No
- 10. Indicate State, Central Sales Tax Registration Number State : Yes/No
Central:
(Please Note that in case of non-registration with Commercial Tax, Department Purchase Tax as admissible shall be deducted by the Purchaser from the Bills of the supplier)
- 11. Please mention whether rates offered are applicable for part quantities. : Yes/No

PLACE:

SIGNATURE OF BIDDER

DATE:

NAME IN FULL
DESIGNATION/STATUS
FIRM/COMPANY SEAL

5.SCHEDULE - III

PART 'C' : TECHNICAL INFORMATION

(Strike off whichever is not applicable. Separate sheets should be used. Wherever necessary)

- 01. Whether material offered is exactly as per technical specification : Yes/No
- 02. Whether the copies of completion certificate received during last 3 years from other State Nodal Agency or from other Organization for supply of inverters (if yes, give details) enclosed. : Yes/No
- 03. Whether pamphlets/technical details literatures along with drawing etc. furnished with the offer : Yes/No (if yes, give details)
- 04. Whether the Bidder agrees to furnish material test certificates in respect of chemical composition and physical properties from Govt./ Govt. approved lab with each batch of supplies. : Yes/No
- 05. Whether the Bidder has furnished details of manufacturing equipments and short history of plant :Yes/No (if yes, give details)
- 06. Whether details of manufacturing process furnished with offer. : Yes/No (if yes, give details)
- 07. a) Whether all testing facilities are available. :Yes/No
If so, give details and in case of non-availability of facilities indicate approved lab available in surrounding areas where tests are proposed to be conducted.

PLACE

SIGNATURE OF BIDDER

DATE

NAME IN FULL

DESIGNATION/STATUS

FIRM/COMPANY

SEAL

6.SCHEDULE - IV
TECHNICAL DEVIATIONS

From,
Bidder Name & Address -

To,
**The CE,
CREDA, HO,
Raipur**

Sub – Technical Deviations.

Dear Sir,

The technical deviations & variations to the specifications stipulated in the Bid, for the item quoted are as under –

S.No	Condition and deviation	Clause no of Bid document	Page no of Bid document	Statement of Variation

2. Except aforesaid deviations, the entire order, if placed, on us shall be executed in accordance with your specifications and other conditions. Variation/deviations etc. if found, elsewhere in our offer should not be given any considerations while finalizing the Bid.

PLACE

SIGNATURE OF BIDDER

DATE

NAME IN FULL

DESIGNATION/STATUS

FIRM/COMPANY SEAL

NOTE - Continuation sheet of like size & format may be used as per bidder's requirements and shall be annexed to this schedule.

7.SCHEDULE - V

PAST EXPERIENCE

From :

Bidder's Name & Address -

To,

The CE,

CREDA, HO,

Raipur

Sub – Performance/Past Experience.

Dear Sir,

We furnish herewith the record of our performance and experience as follows -

-

Sl.No.	Purchaser's Name & Address	Order No. Date	Ordered Quantity	Qty. supplied (Nos.)	Value of Order

-					

-

PLACE

SIGNATURE OF BIDDER

DATE

NAME IN FULL

DESIGNATION/STATUS

FIRM/COMPANY SEAL

NOTE - Photocopy of the completion certificate received from other State Agencies/Govt. Undertakings etc. should be enclosed.

8.ANNEXURE – 19

(EXPERIENCE CERTIFICATE ON THE OFFICIAL LETTER HEAD OF CONCERNED GOVERNMENT DEPARTMENT WITH SEAL AND SIGN BY AUTHORIZED SIGNATORY)

Ref. No.....

Date.....

CERTIFICATE OF SUPPLY OF PDN MATERIAL AND PDN WORKS

This is to certify that **Name of Bidder, Address of Registered Office** has successfully completed the supply/works ofItems/works against various Sanction of Name of Agency at various locations in.....State, as per following details –

Details of Works/Supply	Year	Total Value of work (In Rs.)	Remarks
Total -			

The workmanship and performance of the above Items/work are found satisfactory and are in successful operation.

**Seal & Sign
(Authorised Signatory)**

9. ANNEXURE – 20

FORMAT FOR THE AFFIDAVIT

(Note: This affidavit should be on a non-judicial stamp paper of Rs. 100/- and shall be attested by Magistrate/Sub-Judge/ Notary Public)

I,.....(Name of the bidder authorized representative of the bidder) son/daughter ofresident of(full address), aforesaid solemnly affirm and state as under :

1. I hereby certify that all the information furnished with the bid submitted in response to notice inviting bid number____/CREDA/ HOR/RE-V/AEAS/PDN FAB /2021-22 Dated : XX.XX.2021 issued by Chhattisgarh State Renewable Energy Development Agency (CREDA) (authority inviting bids) for supply of various fabrication items used in PDN works (name and identification of work) are true and correct.
2. I hereby certify that I have been authorized by..... (Company name) to sign on their behalf, the bid mentioned in sr.no.1 above. *
3. Information furnished in the bidding documents is correct in all respects to the best of my knowledge and belief.
4. The near relations as per clause 31(A), in CREDA, are not in employment of the firm/company. (Note:-By the term near relatives is meant Wife, Husband, Parents and Son, Brother, Sister, Brother-in-law, Father-in-law, Mother-in-law etc.) (if working mention the name/names)

.....
.....

5. The name of near relative (if any) as per Clause 31(B) who retired/removed within the last two years. (If None, clearly State None)

.....
.....

6. No near relative is working as Financial Accountant in the CREDA. (if working mention the name)

.....
.....

7. No person is working in the company in any capacity, who are near relatives to any Officer in Chhattisgarh State Renewable Energy Development Agency (CREDA) (If working mention the name)

.....
.....

1. Our company/firm/ or otherwise is not under the clarification of ineligibility for corrupt and fraudulent practices by the Central Government, the State Government or any public undertaking, autonomous body, authority by whatever name called under the Central or the State Government. as mention in clause 1(F) of tender document.
2. I hereby authorize the CREDA Officials to get all the documents verified from appropriate sources (s).

Deponent

Place :

Date :

* Not applicable if the bidder is an individual and is signing the bid on his own behalf.

Verification

I..... S/o.....do here by affirm that contents stated in Para 1 to 09 above and contents submitted in technical & financial bid are true to the best of my knowledge and believe and are based on my/our record.

Verified that this date of at (Place).....

Deponent

10.ANNEXURE – 21

Benchmark cost for fabrication item used in PDN works (Contd.)				
S. No.	Description of Item	Unit	Benchmark Cost per unit (Excl. GST) In Rs	GST as applicable
1	Supply of hot dipped galvanized (in single dip to average 80 micron) Octagonal polemade of 3mm thick steel plate having bases plate 200x200x12mm, Window and flush cover with hacking arrangement at height from base for cable termination block, pole suitably reinforced with welded steel section at window cut section to make the strength of pole unaffected, with 4 nos. 450 mm long, 16mm dia hot dipped GI foundation bolts (EN8 grade)			
1.1	3Meter height Approx Min Weight 27 kg bare pole	Nos	Will be compared with prevailing market rate	
1.2	4Meter height Approx Min Weight 35 kg bare pole	Nos		
1.3	5Meter height Approx Min Weight 42 kg bare pole	Nos		
2	Supply of hot dipped galvanized (in single dip to average 80 micron) Octagonal polemade of 3mm thick steel plate having bases plate 200x200x12mm, Window and flush cover with hacking arrangement at height from base for cable termination block, pole suitably reinforced with welded steel section at window cut section to make the strength of pole unaffected, with 4 nos. 600 mm long, 20mm dia hot dipped GI foundation bolts (EN8 grade)			
2.1	6 Meter height Approx Min Weight 50 kg bare pole	Nos	Will be compared with prevailing market rate	
2.2	7 Meter height Approx Min Weight 57 kg bare pole	Nos		
3	Supply of hot dipped galvanized (in single dip to average 80 micron) Octagonal polemade of 3mm thick steel plate having bases plate 200x200x16mm, Window and flush cover with hacking arrangement at height from base for cable termination block, pole suitably reinforced with welded steel section at window cut section to make the strength of pole unaffected, with 4 nos. 600 mm long, 20mm dia hot dipped GI foundation bolts (EN8 grade)			
3.1	9 Meter height Approx Min Weight 84 kg bare pole	Nos	Will be compared with prevailing market rate	
4	Supply of hot dipped galvanized (in single dip to average 80 micron) Octagonal polemade of 3mm thick steel plate having bases plate 250x250x16mm, Window and flush cover with hacking arrangement at height from base for cable termination block, pole suitably reinforced with welded steel section at window cut section to make the strength of pole unaffected, with 4 nos. 750 mm long, 24mm dia hot dipped GI foundation bolts (EN8 grade)			
4.1	10Meter height Approx Min Weight 101 kg bare pole	Nos	Will be compared with prevailing market rate	

S. No.	Description of Item	Unit	Benchmark Cost per unit (Excl. GST) In Rs	GST as applicable
5	Supply of hot dipped galvanized (in single dip to average 80 micron) Octagonal polemade of 3mm thick steel plate having bases plate 275x275x16mm, Window and flush cover with hacking arrangement at height from base for cable termination block, pole suitably reinforced with welded steel section at window cut section to make the strength of pole unaffected, with 4 nos. 750 mm long, 24mm dia hot dipped GI foundation bolts (EN8 grade)			
5.1	11Meter height Approx Min Weight 133 kg bare pole	Nos	Will be compared with prevailing market rate	
5.2	12Meter height Approx Min Weight 160 kg bare pole	Nos		
6	Fabrication and supply of M.S. Pole, with ISI "B" Class M.S. Pipe as per drawing and specification enclosed with all material and with two coat Zink Chromate primer and tow coat Silver/Aluminium Paint of standard brand 12" x 12" base plate (10 thickness) foundation in MS Pole with stiffener and 4 Nos. T-bolt with double nuts (20 mm. Dia& 900 mm. Length. Nut bolt arrangement in 4 feet from the bottom of pole.			
6.1	5.7 Meter Height Approx Min weight 40-42 kg bare pole	Nos	Will be compared with prevailing market rate	
6.2	7.5 Meter Height Approx Min Weight 80-82 kg bare pole	Nos		
7	Fabrication & Supply of ISI mark G.I.pipe poles made of "B" class making necessary hole for cable entry and providing earthing stud(Welded at specified height) as per specifications and drawing			
7.1	5.7 Meter Height Approx Min weight 45-48 kg bare pole	Nos	Will be compared with prevailing market rate	
7.2	7.5 Meter Height Approx Min weight 62-65 kg bare pole	Nos		
8	Fabrication and supply of ISI mark G.I. special type pedestrian pole as per drawing with 25 watt street light luminary warm LED (4.5 Mtr height) with PU painting as per CREDArequirement,Approx Min Weight -35-38kg including bracket	Nos	Will be compared with prevailing market rate	
9	Fabrication and supply of ISI mark G.I. pedestrian pole as per drawing with street light bracket with PU painting as per CREDA requirement (6 Mtr height),approx Min Weight 45-48 kg including bracket	Nos	Will be compared with prevailing market rate	
10	Fabrication and supply of ISI mark G.I. street light pole as per drawing with street light bracket (9 Mtr height) with PU painting ,Approx min weight -86-89kg including bracket	Nos	Will be compared with prevailing market rate	

S. No.	Description of Item	Unit	Benchmark Cost per unit (Excl. GST) In Rs	GST as applicable
11	Fabrication and supply of ISI mark G.I.cable fixtures Type A,hot dipped galvanized Min Weight:-4.5Kg complete civil material	Nos	Will be compared with prevailing market rate	
12	Fabrication and supply of ISI mark G.I.cable fixtures Type B, hot dipped galvanized Min Weight:-3.0Kg	Nos	Will be compared with prevailing market rate	
13	Fabrication and Supply of ISI mark G.I.pipe "B" Class arrangement(850 mm length and 50 mm dia)for underground cabling in pole near foundation with suitable G.I.clamp for holding ISI mark G.I.pipe "B" Class	Nos.	Will be compared with prevailing market rate	
14	Fabrication & Supply of G.I. stay sets as per specifications and drawing	Nos.	Will be compared with prevailing market rate	
15	Fabrication & supply of ISI mark G.I.pipe "B" Class street light bracket for mounting Street Light fittings as per specifications and drawing.Approx Min weight 2.75-3.5kg	Nos.	Will be compared with prevailing market rate	
16	Fabrication & supply of ISI mark hot dipped G.I. Single arm street light bracket(Size OD 48.3x3.20 MM Thick,Length 1.5Mtr Centre to top with 15' inclination from horizontal plane) for mounting Street Light fittings in octagonal pole of various height as per specifications and drawing.Pipe Material IS:2062 (Min Approx weight 08 kg bare)	Nos.	Will be compared with prevailing market rate	
17	Fabrication & supply of ISI mark hot dipped G.I. Double arm street light bracket(Size OD 48.3x3.20 MM Thick,Length 1.5Mtr Centre to top with 15' inclination from horizontal plane) for mounting Street Light fittings in octagonal pole of various height as per specifications and drawing.Pipe Material IS:1161,YST:210Mpa (Min Approx 13 kg bare)	Nos.	Will be compared with prevailing market rate	
18	Fabrication & supply of ISI mark G.I.pipe "B" Class Wall Mount Brackets as per specifications and drawing	Nos.	Will be compared with prevailing market rate	
19	Fabrication and supply of hot dipped galvanised structure for mounting of solar modules or any other structure as per specification,size and design given with all required material,drilling work and two coat steel primer zinc chromate of standard quality	per Kg	Will be compared with prevailing market rate	

END